



High-end Sound Quality Upgraded Audio Media Player

UTX-A09



Please read before using this equipment.

ALPINE ELECTRONICS MARKETING, INC.

1-7, Yukigaya-Otsukamachi, Ota-ku,
Tokyo 145-0067, JAPAN
Phone: 03-5499-4531

ALPINE ELECTRONICS OF AMERICA, INC.

19145 Gramercy Place, Torrance,
California 90501, U.S.A.
Phone 1-800-ALPINE-1 (1-800-257-4631)

ALPINE ELECTRONICS OF AUSTRALIA PTY.

LTD.
161-165 Princes Highway, Hallam
Victoria 3803, Australia
Phone 03-8787-1200

ALPINE ELECTRONICS GmbH

Wilhelm-Wagenfeld-Str. 1-3, 80807 München, Germany
Phone 089-32 42 640

ALPINE ELECTRONICS OF U.K. LTD.

Alpine House
Fletchamstead Highway, Coventry CV4 9TW, U.K.
www.alpine.co.uk

ALPINE ELECTRONICS FRANCE S.A.R.L.

184 allée des Erables
CS 52016 - Villepinte
95 945 Roissy Charles CDG Cedex
France
Phone: + 33(0)1 48 63 89 89

ALPINE ITALIA S.p.A.

Viale Cristoforo Colombo 8,
20090 Trezzano Sul Naviglio (MI), Italy
Phone +39 02 484781

ALPINE ELECTRONICS DE ESPAÑA, S.A.

Portal de Gamarra 36, Pabellón, 32
01013 Vitoria (Alava)-APDO 133, Spain
Phone 945-283588

ALPINE ELECTRONICS (China) Co., Ltd.

R2-4F, CHINA MERCHANTS TOWER
NO. 116, JIANGUO STREET,
CHAOYANG DISTRICT
BEIJING 100022, CHINA

Operating Instructions

WARNING



This symbol means important instructions. Failure to heed them can result in serious injury or death.

DO NOT OPERATE ANY FUNCTION THAT TAKES YOUR ATTENTION AWAY FROM SAFELY DRIVING YOUR VEHICLE.

Any function that requires your prolonged attention should only be performed after coming to a complete stop. Always stop the vehicle in a safe location before performing these functions. Failure to do so may result in an accident.

KEEP THE VOLUME AT A LEVEL WHERE YOU CAN STILL HEAR OUTSIDE NOISES WHILE DRIVING.

Excessive volume levels that obscure sounds such as emergency vehicle sirens or road warning signals (train crossings, etc.) can be dangerous and may result in an accident. LISTENING AT LOUD VOLUME LEVELS IN A CAR MAY ALSO CAUSE HEARING DAMAGE.

DO NOT DISASSEMBLE OR ALTER.

Doing so may result in an accident, fire or electric shock.

USE ONLY IN CARS WITH A 12 VOLT NEGATIVE GROUND.

(Check with your dealer if you are not sure.) Failure to do so may result in fire, etc.

KEEP SMALL OBJECTS SUCH AS BATTERIES OUT OF THE REACH OF CHILDREN.

Swallowing them may result in serious injury. If swallowed, consult a physician immediately.

USE THE CORRECT AMPERE RATING WHEN REPLACING FUSES.

Failure to do so may result in fire or electric shock.

DO NOT BLOCK VENTS OR RADIATOR PANELS.

Doing so may cause heat to build up inside and may result in fire.

USE THIS PRODUCT FOR MOBILE 12V APPLICATIONS.

Use for other than its designed application may result in fire, electric shock or other injury.

DO NOT PLACE HANDS, FINGERS OR FOREIGN OBJECTS IN INSERTION SLOTS OR GAPS.

Doing so may result in personal injury or damage to the product.



This symbol means important instructions. Failure to heed them can result in injury or material property damage.

HALT USE IMMEDIATELY IF A PROBLEM APPEARS.

Failure to do so may cause personal injury or damage to the product. Return it to your authorized Alpine dealer or the nearest Alpine Service Centre for repairing.



Product Cleaning

Use a soft dry cloth for periodic cleaning of the product. For more severe stains, please dampen the cloth with water only. Anything else has the chance of dissolving the paint or damaging the plastic.

Temperature

Be sure the temperature inside the vehicle is between +60°C and -10°C before turning your unit on.

Maintenance

If you have problems, do not attempt to repair the unit yourself. Return it to your Alpine dealer or the nearest Alpine Service Center for servicing.

Installation Location

Make sure this unit will not be installed in a location subjected to:

- Direct sunlight and heat
 - High humidity and water
 - Excessive dust
 - Excessive vibrations
-

Protecting the USB Connection Terminals

- This unit provides a front USB terminal and a rear one. The rear connector supports connection and use of iPhone/iPod/MTP/USB Memory. The front terminal can connect USB Memory/MPT only. Correct performance of this unit cannot be guaranteed if both front and rear terminals connect charging equipment (e.g. iPhone/iPod/MTP).
 - Only a USB Memory, MTP or iPod/iPhone can be connected to the USB terminal on this unit. Correct performance using other USB products cannot be guaranteed.
 - If the USB connector is used, be sure to use a USB extension cable (supplied). A USB hub is not supported.
 - Depending on the connected USB Memory/MTP, the unit may not function, or some functions may not be performed.
 - The file systems supported by the unit are FAT16, FAT32, and ex FAT.
 - Be sure the number of songs in the connected USB memory/MTP (the total number of songs in both USB memories connected to the front and rear terminals) will not exceed 10,000. Otherwise, the unit may fail to play songs properly.
 - The audio file format that can be played back on the unit is MP3/WMA/AAC/FLAC/WAV/APE.
 - Artist/song name, etc. can be displayed. However, some particular characters may not be correctly displayed.
-

On Handling USB Memory



Alpine accepts no responsibility for lost data, etc., even if data, etc., is lost while using this product.

- To prevent malfunction or damage, note the following points.
 - Read the USB Memory Owner's Manual thoroughly.
 - Do not touch the terminals by hand or metal.
 - Do not subject USB Memory to excessive shock.
 - Do not bend, drop, disassemble, modify or soak in the water.
- Avoid usage or storage in the following locations:
 - Anywhere in the car exposed to direct sunlight or high temperature.
 - Anywhere the possibility of high humidity or corrosive substances is present.
- Fix the USB Memory in a location where driver operation will not be hindered.
- USB Memory may not function correctly at high or low temperature.
- The USB Flash Memory supports only 512 or 2,048 bytes per sector.
- Use only certified USB Memory. Note that even certified USB Memory may not function correctly depending on its type or state.
- USB Memory function is not guaranteed. Use USB Memory according to the terms of agreement.
- Depending on the settings of the USB Memory type, memory state or encoding software, the unit may not play back or display properly.
- A file that is copy-protected (copyright protection) cannot be played back.
- USB Memory may take time to start playback. If there is a particular file other than audio in the USB Memory, it may take considerable time before the file is played back or searched.
- The unit can play back the files with "mp3", "wma", "m4a", "wav", "flac", or "ape" extension.
- Do not add the above extension to a file other than audio data. This non-audio data will not be recognized. The resulting playback may contain noise that can damage speakers and/or amplifiers.
- It is recommended to back up important data on a personal computer.
- Do not remove the USB device while playback is in progress. Change SOURCE to something other than USB, and then remove the USB device to prevent possible damage to its memory.

- *iPhone, iPod touch and Lightning are trademarks of Apple Inc., registered in the U.S. and other countries.*
- *The use of Apple logos means that the product has been designed to connect specified Apple products and has been certified by the developer to meet Apple performance standards. Apple is not responsible for the operation of this device or its compliance with safety and regulatory standards. Please note that the connection with iPod or iPhone may affect wireless performance.*
- *Android is a trademark of Google Inc.*
- *The Android robot is reproduced or modified from work created and shared by Google and used according to terms described in the Creative Commons 3.0 Attribution License.*
- *Windows Media is a trademark or registered trademark of Microsoft Corporation in the United States and/or other countries.*
- *The BLUETOOTH word mark and logos are registered trademarks owned by the Bluetooth SIG, Inc. and any use of such marks by Alpine Electronics, Inc. is under license.*
- *The products with High-Resolution mark comply with the benchmark defined by Japan Audio Society. The use of High-Resolution mark has been authorized by Japan Audio Society.*
- *MPEG Layer-3 audio coding technology licensed from Fraunhofer IIS and Thomson. Supply of this product only conveys a license for private, noncommercial use and does not convey a license nor imply any right to use this product in any commercial (i.e. revenue generation) real time broadcasting (terrestrial, satellite, cable and/or any other media), broadcasting/streaming via internet, intranets and/or other networks or in other electronic content distribution systems, such as pay-audio or audio-on-demand applications. An independent license for such use is required. For details, please visit <http://www.mp3licensing.com>.*

GETTING STARTED

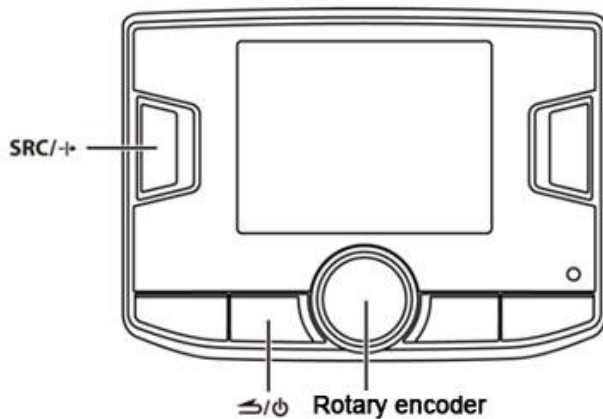

Accessory List

• Head unit	1
• Power cable.....	1
• USB cable.....	1
• AUX/Pre-output cable.....	1
• Microphone.....	1
• Mounting bracket.....	2
• Round head screw (M5 × 8)	8
• Controller.....	1
• Controller cable	1
• Controller tray.....	1
• Controller bracket.....	1
• Light shield.....	1
• Adhesive tape.....	1 set
• Owner's Manual.....	1 set

Turning Power on and off

Press any button on the controller to turn on the unit.

Press and hold  for at least 2 seconds to turn off the unit.

Note

- *The first time power is turned on, the volume will start from level 12.*
-

Setting AUX Mix Mode

High-quality audio processing chip has been present in this unit. You may choose ALPINE Direct Mode to appreciate the high-quality signal source of this unit or choose AUX Mix Mode to listen to the voice of original vehicle equipment (e.g. navigator) while appreciating the signal source of this unit.

Press and hold **SRC/→** for at least 2 seconds to switch to AUX Mix Mode.

AUX Mix (initial setting)  ALPINE Direct

Aux Mix:

When the unit plays music, mix the music played by vehicle sound system with the voice navigation prompts.

ALPINE Direct:

Only appreciate the high-quality music brought by UTX-A09.

Note

- When the source is AUX, it cannot switch to AUX Mix Mode.
 - Before using this function, make sure the audio output of vehicle sound system is correctly connected to AUX IN of the unit. For details, please read "Connection".
-

Source Selection

Press **SRC/→** to change the source.

FM → AM → USB*1 → iPod*2 → AUX → Bluetooth Audio*3 → FM

*1 *When the unit connects two USB memories, the audio files will be played as a single USB source.*

*2 *Displayed only when the iPod/iPhone supported by this unit is connected. Please connect iPod/iPhone to the rear USB terminal.*

*3 *Displayed only when Bluetooth Audio is set to ON. Refer to "Setting the BLUETOOTH Connection".*

Initial System Startup

Be sure to press the **RESET** switch when using the unit for the first time or after changing the car battery, etc.

- 1 Turn off the unit power.
- 2 Press **RESET** with a ballpoint pen or similar pointed object.

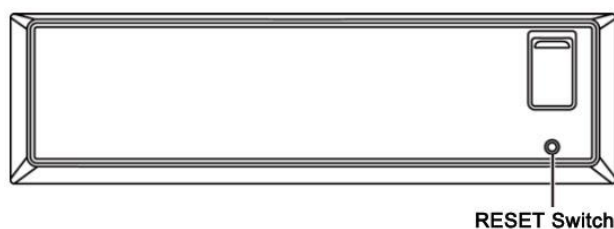

Adjusting Volume

Turn the **Rotary encoder** until the desired sound is obtained.

Control the unit by using the optional controller:

Aim the controller transmitter at the remote sensor.

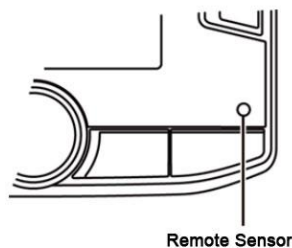

Connect it to the controller connector

You may control the unit by using the steering wheel controls through the optional Alpine steering wheel controller connector. For details, please contact your authorized Alpine dealer.

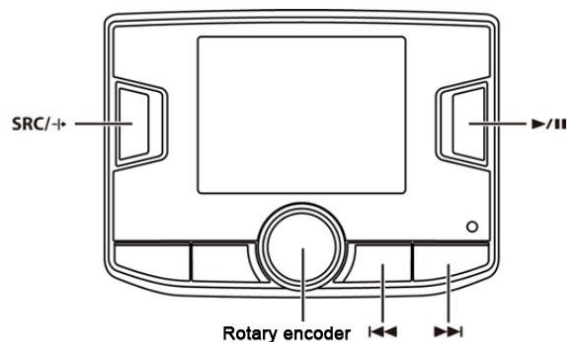

Listening to Radio

- 1 Press **SRC/+** to select FM or AM mode.
- 2 Press **▶/||** to select TUNER mode.
AUTO SEEK (automatic mode) ↔ MANUAL SEEK (manual mode)

Note

- *The initial mode is automatic mode.*

Automatic mode:

Automatically search TUNER.

Manual mode:

Manually tune the frequency level by level (manual tuning).

- 3 Press **◀◀** or **▶▶** to recall the desired radio station.
Holding **◀◀** or **▶▶**, you will switch to the preset radio station.

Presetting Stations Manually

- 1 Press the Rotary encoder in FM or AM mode.
- 2 Turn the Rotary encoder to select any preset number (1-12 or 1-6) in the memory list.
- 3 Press and hold the Rotary encoder for at least 2 seconds.

The current radio station is stored into the preset button selected by you.

Note

- A total of 18 stations can be stored in the preset memory (12 stations for FM band; 6 stations for AM band).
 - If you store a station in a preset memory which already has a station, the current station will be cleared and replaced with the new station.
-

Presetting Stations Automatically

- 1 Press **SRC/→** to select FM or AM.
- 2 Press the Rotary encoder.
- 3 Turn the Rotary encoder to select “Presetting Stations Automatically”, and press the Rotary encoder.

The tuner will automatically seek and store 12 (or 6 for AM band) strong stations in the selected band. They will be stored into preset buttons in ascending order of frequency.

Tuning to Preset Stations

- 1 Press the Rotary encoder in FM or AM mode.
- 2 Turn the Rotary encoder to select a preset station in the memory list.
- 3 Press the Rotary encoder to receive the station selected.

The display shows the preset number and frequency of the station selected.

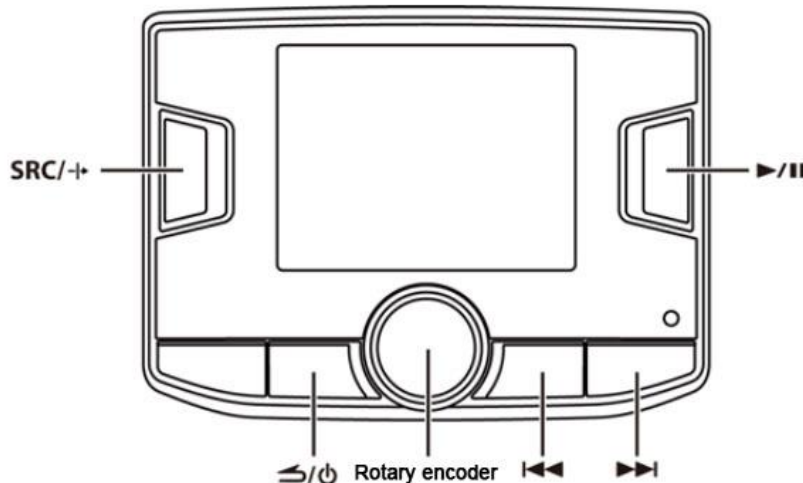

Note

- When the unit connects two USB memories at the same time, the system will automatically play the contents in both USB memories.
 - Do not connect two charging devices concurrently to the USB terminal of this unit. If you do so, normal performance cannot be guaranteed.
 - The unit is compatible with a mobile phone supporting MTP.
-

Connecting USB Memory / MTP (Optional)

If you connect a USB memory / MTP device to the unit, it can play MP3/WMA/AAC/WAV/FLAC/APE files.

Playback

- 1 Press **SRC/→** to select USB mode.
- 2 Touch **◀◀** or **▶▶** to select the desired track (file).
Pressing and holding **◀◀** or **▶▶** will fast backward/fast forward track continuously.
- 3 To pause playback, press **▶/||**.
Pressing **▶/||** again will resume playback.

Note

- Depending on the file stored in USB/MTP, it may take some time to start playback.
 - During playback, the screen will display the format of file played.
 - When it plays a high-resolution (Hi-Res) audio file, the screen will display HR icon.
 - Any file protected by DRM (Digital Rights Management) copy protection, cannot be played back on this unit.
 - The playback time may not be correctly displayed when a VBR (Variable Bit Rate) recorded file is played back.
 - If the file contains tag information, the song name / artist name / album name will be displayed.
 - The unsupported characters will be replaced with “□” when displayed.
-

Repeat Play

- 1 Press **↶**.
The song is played back repeatedly.

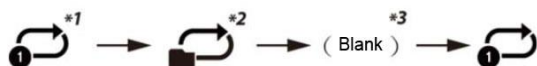

- *1 Only a track/file is repeatedly played back.
- *2 Only files in a folder are repeatedly played back (it works after searching by folder).
- *3 Repeat Play is turned off.

- 2 To cancel Repeat Play, turn off this function by following the above procedure.
-

Searching for a desired Song

A USB memory can contain many songs. Search by folder or category to find a desired song rapidly.

- 1 Press the Rotary encoder to activate the search mode.
- 2 Turn the Rotary encoder to select “Searching by folder” or Searching by category”, and press the Rotary encoder.

Searching by folder

Searching by folder will display all valid folders in USB/MTP. Then rapidly find a desired song.

- 3 Turn the Rotary encoder to select a desired folder, and press the Rotary encoder.

Note

- An empty folder or a folder with no valid file will not be displayed.

Searching by category

In this mode, you can choose to search by song/artist/album.

- 3-1 Turn the Rotary encoder to choose searching by song, artist or album, and press the Rotary encoder.

3-2 Turn the Rotary encoder to select a desired song, artist or album, and press the Rotary encoder.

If searching by song is chosen at this step, it will directly play the selected song. You do not need to perform the next step.

If two USB memories are connected at the same time, the system will automatically merge the song categories in both USB memories.

4 Turn the Rotary encoder to choose a song of the selected folder, artist or album, and press the Rotary encoder.

Start to play back the selected song.

Note

- *Searching may be slow if many songs are stored in USB/MTP.*

About MP3/WMA/AAC/WAV/FLAC/APE

CAUTION

Except for private use, duplicating audio data (including MP3/WMA/AAC/WAV/FLAC/APE data) or distributing, transferring, or copying it, whether for free or for a fee, without permission of the copyright holder is strictly prohibited by the Copyright Act and by international treaty.

What is MP3?

MP3, whose official name is “MPEG Audio Layer 3”, is a compression standard prescribed by the ISO (the International Standardization Organization) and MPEG which is a joint activity institution of the IEC. MP3 files contain compressed audio data. MP3 encoding is capable of compressing audio data at extremely high ratios, reducing the size of music files to as much as one-tenth their original size. This is achieved while still maintaining near CD quality. The MP3 format realizes such high compression ratios by eliminating the sounds that are either inaudible to the human ear or masked by other sounds.

What is WMA?

WMA or “Windows Media™ Audio” is compressed audio data. WMA is similar to MP3 audio data.

What is AAC?

AAC is the abbreviation for “Advanced Audio Coding” and a basic format of audio compression used by MPEG2 or MPEG4.

What is WAV?

WAV is an audio file format developed by Microsoft Corporation, and conforms to RIFF (Resource Interchange File Format) file specification. It is used to store audio information resources of the Windows platform and is widely supported by Windows platform and its applications. The WAV format supports various compression algorithms such as MSADPCM and CCITT A LAW. It supports multiple audio bits, sampling rates and channels. The standard format WAV file is the same as the CD format. It is also a 44.1 kHz sampling frequency with 16 quantized bits. Therefore, WAV format sound file quality is almost the same as CD. As this is the most lossless music format, the file size is relatively large.

What is FLAC?

FLAC is a lossless audio compression encoding format. FLAC is a set of famous free lossless audio codec characterized by lossless compression. Different from other lossy compression encoding formats such as MP3 and AAC, this format does not damage any original audio information.

What is APE?

APE is one of the popular lossless compression formats for digital music. Different from MP3, a lossy compression format that irreversibly deletes data (insensitive to human hearing) to reduce the size of source file, APE is a lossless compression format that reduces file size by a more refined way of recording, and restored data are the same as source file, thus guarantee the completeness of file.

Method for creating MP3/WMA/AAC/WAV/FLAC/APE (USB Drive) files

Audio data is compressed using software with MP3/WMA/AAC/WAV/FLAC/APE codec. For details on creating MP3/WMA/AAC/WAV/FLAC/APE files, refer to the user’s manual for that software. MP3/WMA/AAC/WAV/FLAC/APE (USB Drive) files that are playable on this device have the file extensions as below:

MP3: “mp3”

WMA: “wma”

AAC: “m4a”

WAV: “wav”

FLAC: “flac”

APE: “ape”

Files with no extension cannot be played back. WMA Lossless and WMA Professional files are not supported. Protected files are not supported. Neither are

raw AAC files (using the ".aac" extension).

There are many different versions of the AAC format. Confirm that the software being used conforms to the acceptable formats listed above. It's possible that the format is unplayable even though the extension is valid.

Playback of AAC files encoded by iTunes is supported. APE decoding only corresponds to APE v2 label.

Supported playback sampling rates and bit rates

MP3

Sampling rates: 48 kHz, 44.1 kHz, 32 kHz, 24 kHz, 22.05 kHz, 16 kHz, 12 kHz, 11.025 kHz, 8 kHz

Bit rates: 8 - 320 kbps

WMA

Sampling rates: 48 kHz, 44.1 kHz, 32 kHz, 22.05 kHz, 16 kHz, 11.025 kHz, 8 kHz

Bit rates: 12 - 192 kbps (stereo)
0-128 kbps (monaural)

AAC

Sampling rates: 48 kHz, 44.1 kHz, 32 kHz, 24 kHz, 22.05 kHz, 16 kHz, 12 kHz, 11.025 kHz, 8 kHz

Bit rates: 8 - 320 kbps

WAV

Sampling rates: 192 kHz, 176.4 kHz, 96 kHz, 88.2 kHz, 48 kHz, 44.1 kHz, 32 kHz, 24 kHz, 22.05 kHz, 16 kHz

Quantized bit: 8 bit, 16 bit, 24 bit

FLAC

Sampling rates: 192 kHz, 176.4 kHz, 96 kHz, 88.2 kHz, 48 kHz, 44.1 kHz, 32 kHz, 24 kHz, 22.05 kHz, 16 kHz, 12 kHz, 11.025 kHz, 8 kHz

Quantized bit: 16 bit, 24 bit

APE

Sampling rates: 192 kHz, 176.4 kHz, 96 kHz, 88.2 kHz, 48 kHz, 44.1 kHz, 32 kHz, 24 kHz, 22.05 kHz, 16 kHz, 12 kHz, 11.025 kHz, 8 kHz

Quantized bit: 8 bit, 16 bit, 24 bit

Depending on the sampling rates, the device may not play back correctly.

The playback time may not be correctly displayed when a VBR (Variable Bit Rate) recorded file is played back in the USB mode.

Playing back MP3/WMA/AAC/WAV/FLAC/APE

MP3/WMA/AAC/WAV/FLAC/APE files are prepared, then stored to a USB Memory/MTP (mobile phone).

- Maximum number of files/folders that can be played back

USB Memory/MTP (mobile phone): 10,000 files / 700 folders (including the root folder)

- Maximum nested folder depth is 8 (including the root folder)

Playback may not be performed if the USB Memory/MTP (mobile phone) exceeds the limitations described above.

Do not make the file playback time more than 1 hour.

RSA Data Security, Inc. MD5 Message-Digest Algorithm

Media supported

This device can play back USB Memory/MTP (mobile phone) media.

Corresponding File Systems

This device supports FAT 16/32 for USB Memory/MTP (mobile phone).

Order of files

Files are played back in the order that the files/folders are stored in the USB Memory/MTP (mobile phone). Therefore, the playback order may not be what is expected. The playback order of the folders and files is as follows.

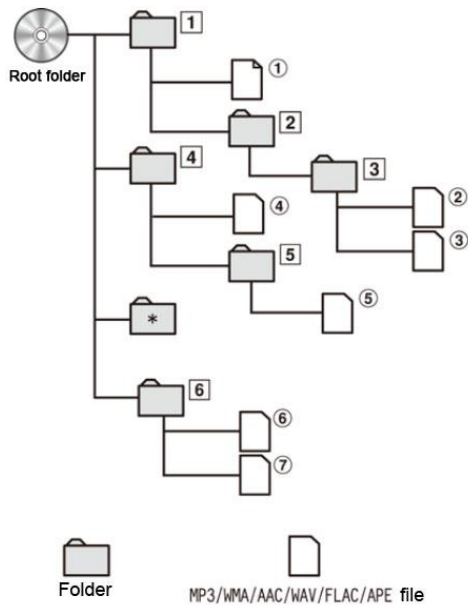

* The folder No./Folder Name will not be displayed if the folder is empty or has no valid file.

Terminology

Bit rate

This is the “sound” compression rate specified for encoding. The higher the bit rate, the higher the sound quality, but also the larger the files.

Sampling rate

This value shows how many times per second the data is sampled (recorded). For example, music CDs use a sampling rate of 44.1 kHz, so the sound is sampled (recorded) 44,100 times per second. The higher the sampling rate, the higher the sound quality, but also the larger the volume of data.

Encoding

Converting music CDs, WAVE (AIFF) files, and other sound files into the specified audio compression format.

Tag

Song information such as track titles, artist names, album names, etc., written into MP3/WMA/AAC/WAV/FLAC/APE files.

Root folder

The root folder (or root directory) is found at the top of the file system. The root folder contains all folders and files.

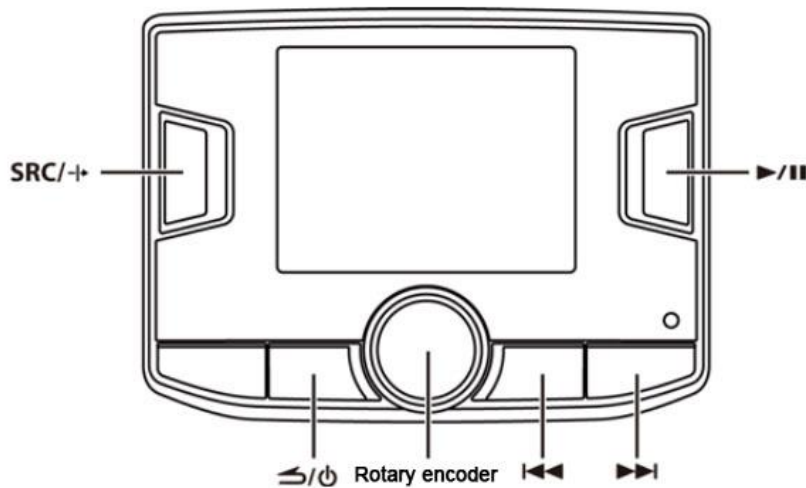

Audio Setup

You can flexibly customize the unit to suit your own preference and usage. From the Sound Setting menu, Audio Setup can be modified.

Use steps 1 to 5 to select any setting mode you wish to modify. For details on how to change each setting, see the applicable sections below.

- 1 Press and hold the Rotary encoder for at least 2 seconds to activate the SETUP mode.
- 2 Turn the Rotary encoder to select SOUND, and then press the Rotary encoder.
Sound*1 ↔ Normal ↔ Bluetooth
- 3 Turn the Rotary encoder to select the desired sound setting menu, and then press the Rotary encoder.
EQ PRESETS*1/*2/*3 ↔ BASS*4/*5 ↔ TREBLE*2/*4 ↔ PARAMETRIC EQUALIZER*2/*3 ↔ SUBWOOFER ↔ LEFT/RIGHT BALANCE ↔ FRONT/REAR BALANCE*5 ↔ AUX MIX ADJUSTMENT*6 ↔ MX HD*2/*7 ↔ ADJUSTING TIME CORRECTION ↔ CROSSOVER SETUP*8 ↔ DEFEAT SETTING ↔ BUILT-IN AMPLIFIER SWITCH ↔ COAXIAL/OPTICAL SWITCH ↔ STORING SOUND SETTING
- 4 Turn the Rotary encoder to change the setting or proceed to the next level, and then press the Rotary encoder.
- 5 Press **SRC/→** to disable the setting mode.

Note

- Pressing **↵** returns to the previous Sound menu mode.

Equalizer Presets

10 typical equalizer settings are preset at the factory for a variety of musical source material.

FLAT (Initial setting) ↔ POPS ↔ ROCK ↔ NEWS ↔ JAZZ ↔ HIP HOP ↔ EASY LIS ↔ COUNTRY ↔ CLASSICAL ↔ CUSTOMIZE

Note

- The 9-Band, Parametric EQ is used to customize the EQ PRESETS settings. After adjusting BASS/TREBLE or PARAMETRIC EQUALIZER, the "CUSTOMIZE" item will display.

Adjusting the Bass/Treble Level

You can adjust the Bass/Treble level according to your preference.

Setting item: BASS/TREBLE

Setting contents: -7~+7 (Initial setting: 0)

Adjusting the Parametric Equalizer Curve

You can modify the Equalizer settings to create a response curve more appealing to your personal taste.

- 1 After selecting Parametric Equalizer from the Sound mode, turn the Rotary encoder to select the desired band, and then press the Rotary encoder.
- 2 Press the Rotary encoder after selecting the frequency. Turn the Rotary encoder to select the frequency value.
Press to **↵** exit frequency setting.
- 3 Repeat Step 2 to adjust the bandwidth and level in the selected band.

Adjusting the Band

Setting contents:

Band 1/Band 2/Band 3/Band 4/Band 5/Band 6/Band 7/Band 8/Band 9

Adjusting the Frequency

Adjustable frequency bands: 20 Hz to 20 kHz

Band 1:	20 Hz ~ 100 Hz (63 Hz)
Band 2:	63 Hz ~ 315 Hz (125 Hz)
Band 3:	125 Hz ~ 500 Hz (250 Hz)
Band 4:	250 Hz ~ 1 kHz (500 Hz)
Band 5:	500 Hz ~ 2 kHz (1 kHz)
Band 6:	1 kHz ~ 4 kHz (2 kHz)
Band 7:	2 kHz ~ 7.2 kHz (4 kHz)
Band 8:	5.8 kHz ~ 12 kHz (8 kHz)
Band 9:	9 kHz ~ 20 kHz (16 kHz)

Adjusting the Bandwidth (Q)

Setting contents:

3.0 (Initial setting) / 4.0 / 5.0

Note

- Settings exceeding the frequency of adjacent bands are not available.
- While adjusting the Parametric Equalizer, you should consider the frequency response of the connected speakers.
- When adjusting the Parametric Equalizer, the adjusted EQ PRESETS will become invalid.

Adjusting the Level

Setting content:

-7 to +7 (Initial setting: 0)

Note

- Settings exceeding the frequency of adjacent bands are not available.
- While adjusting the Parametric Equalizer, you should consider the frequency response of the connected speakers.
- Adjusting the Parametric Equalizer displays the screen to customize the EQ PRESETS settings.

Setting Subwoofer

Turning Subwoofer ON/OFF

When the subwoofer is on, you can adjust the subwoofer phase output level.

■ Setting item: SUBWOOFER

Setting contents:

OFF / ON (Initial setting)

OFF:

No subwoofer signal is output from the Subwoofer RCA Connectors (refer to "[Connections](#)").

ON:

The subwoofer signal is output from the Subwoofer RCA Connectors (refer to "[Connections](#)").

Setting the Subwoofer Phase

The subwoofer output phase is toggled between 0° (NORMAL) and 180° (REVERSE). Turn the Rotary encoder to adjust the phase.

■ Setting item: SUBW PHASE

Setting contents:

0° (Initial setting) / 180°

Setting the Subwoofer Level

When the subwoofer is on, you can adjust the subwoofer output level.

- **Setting item:** SUBW LEVEL
Setting contents: 0~15 (Initial setting: 0)

Adjusting the Speaker Output Balance between Left and Right

- **Setting item:** LEFT/RIGHT BALANCE
Setting contents: L15~0~R15 (Initial setting: 0)

Adjusting the Speaker Output Balance between Front and Rear

- **Setting item:** FRONT/REAR BALANCE
Setting contents: F15~0~R15 (Initial setting: 0)

Adjusting the AUX MIX Level

After selecting the AUX MIX mode, you can set the AUX MIX output level.

- **Setting item:** AUX MIX ADJUSTMENT
Setting contents: 0~12 (Initial setting: 6)

Setting MX HD Mode

MX HD makes the sound of a person or musical instrument clearer regardless of the source. The music can be clearly reproduced from USB, iPod, etc even in the vehicle on a very noisy road.

- **Setting item:** MX HD
Adjustable sources (media) and settings
FM/Compressed Media/AUX: OFF (Initial setting)/Level 1/Level 2/Level 3

Note

- MX HD settings are only applicable to the source being played.
- The sources corresponding to compressed media are iPod, USB, and Bluetooth Audio.
- The MX mode is not available for AM radio.

Adjusting the Time Correction

Before performing the following procedures, refer to "[About Time Correction](#)".

- 1 After selecting "Adjusting the Time Correction" from the Sound Setting mode, turn the Rotary encoder to select the speaker or time correction unit option to be adjusted, and then press the Rotary encoder.

FRONT-L ↔ FRONT-R ↔ REAR-L ↔ REAR-R ↔ LEFT SUBWOOFER* ↔ RIGHT SUBWOOFER*

* Adjustment cannot be performed when the SUBWOOFER mode is off.

- 2 Turn the Rotary encoder to adjust the distance or time correction unit of the selected speaker, and then press the Rotary encoder.

0.0 cm to 336.6 cm (3.4cm/step)

0.0 inch to 132.7 inch (1.3inch/step)

0.0 to 9.9msec (0.1msec/step)

Such settings make the sound of this speaker to reach the listening position at the same time as the sound of other speakers.

Note

- The total adjustment distance for all speakers should be less than 510 centimeters/201 inches/15 milliseconds.
- Time correction units that can be selected: cm (Initial setting) / inch / msec

Adjusting the Crossover Settings

Before performing the following procedures, refer to "[About the Crossover](#)".

- 1 After selecting Crossover Settings from the Audio Setup mode, turn the Rotary encoder to select the desired channel, and then press the Rotary encoder.

- **Active 2-way mode**
FRONT SPEAKER ↔ REAR SPEAKER ↔ SUBWOOFER*¹

■ Active 3-way mode

LOW ↔ MID LOW ↔ MID HIGH ↔ HIGH

*1 Adjustment cannot be performed when the SUBWOOFER mode is off.

- 2 Turn the Rotary encoder to select the desired setting item, and then press the Rotary encoder.

Setting the Cut-off Frequency

■ Active 2-way mode

Setting contents:

20 / 25 / 31.5 / 40 / 50 / 63 / 80 (Initial setting) / 100 / 125 / 160 / 200 (Hz)

■ Active 3-way mode

Setting contents:

LOW/MID LOW*:

20 / 25 / 31.5 / 40 / 50 / 63 / 80 / 100 / 125 / 160 / 200 / 250 / 315 / 400 / 500 (Initial setting) / 630 / 800 (Hz)

MID HIGH:

20 / 25 / 31.5 / 40 / 50 / 63 / 80 / 100 / 125 / 160 / 200 / 250 / 315 / 400 / 500 / 630 / 800 / 1 k / 1.2 k / 1.6 k / 2 k / 2.5 k / 3.2 k / 4 k / 5 k (Initial setting) / 6.3 k / 8 k / 10 k / 12.5 k / 16 k / 20 k (Hz)

HIGH:

1 k / 1.2 k / 1.6 k / 2 k / 2.5 k / 3.2 k / 4 k / 5 k (Initial setting) / 6.3 k / 8 k / 10 k / 12.5 k / 16 k / 20 k (Hz)

* The cut-off frequency setting of MID LOW should not be more than that of MID HIGH.

Adjusting the Slope

Setting contents:

FLAT* / 6 / 12 (dB/oct.)

* In the 3-way mode, HIGH does not correspond to FLAT.

Note

The initial setting of active 2-way mode is FLAT, and the initial setting of active 3-way mode is 12.

Adjusting the Level

Setting contents:

-12dB~0dB (Initial setting: 0)

DEFEAT Setting

When DEFEAT is turned on, the sound effect related settings such as EQ PRESETS will become invalid. Turning DEFEAT off can return to the previous sound effect setting.

■ Setting item: DEFEAT Setting

Setting contents: OFF (Initial setting) / ON

Turning the Built-in Amplifier ON/OFF

Connecting to an External Amplifier

When an external amplifier is connected, sound quality can be improved by stopping the power supply of the built-in amplifier.

■ Setting item: BUILT-IN AMPLIFIER SWITCH

Setting contents:

OFF / ON (Initial setting)

OFF:

Use this mode when the pre-output of this unit is used to drive an external amplifier. In this setting, the head unit's internal amplifier is turned OFF and cannot drive speakers.

ON:

The speakers are driven by the built-in amplifier.

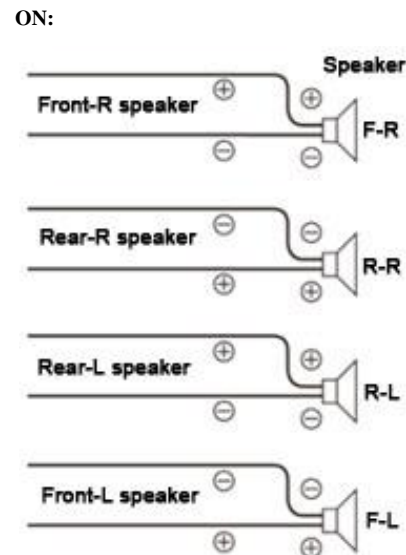
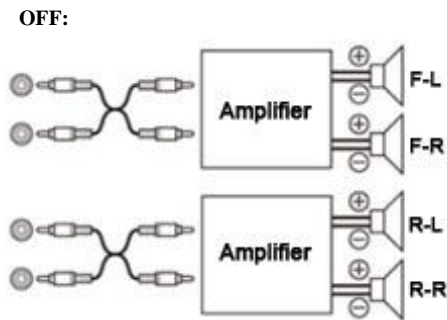

Note

- No sound is produced by the system when the Built-in Amplifier Switch is set to OFF.

Setting Coaxial/Optical Switch

This function is turned ON when the unit connects the devices such as PXE-0850 Amplifier or PXA-H800 Audio Processor.

Generally, the output from coaxial terminal and optical fiber has similar audio quality. Select the coaxial or optical connector, depending on the model of connected amplifier or processor.

COAXIAL/OPTICAL SWITCH

Setting contents: OFF (Initial setting) / ON

Storing and Recalling Sound Setting Parameters

Storing Sound Setting Parameters

After this unit is purchased from and installed by an authorized Alpine dealer, the technical professionals will debug and store relevant sound setting parameters in Dealer Setup.

In addition to Dealer Setup, if you have your own preferences, you can select Customized Setup after setting the sound parameters such as EQ PRESETS, BASS, TREBLE, and CROSSOVER SETUP. Press and hold **▶/||** for at least 2 seconds to store the debugged sound parameters in Customized Setup.

Recalling Stored Sound Setting Parameters

After selecting Dealer Setup or Customized Setup, press **▶/||** to recall the debugged sound setting parameters.

Note

- The stored contents will not be deleted even when you reset the unit or disconnect the battery.

About Time Correction

The distance between the listener and the speakers in a car vary widely due to the complex speaker placement. This difference in the distances from the speakers to the listener creates a shift in the sounds image and frequency characteristics. This is caused by the time delay between the sound reaching the listener's right versus the left ear.

To correct this, this unit is able to delay the audio signal to the speakers closest to the listener. This effectively creates a perception of increased distance for those speakers. The listener can be placed at an equal distance between the left and right speakers for optimum staging. The adjustment will be made for each speaker in 3.4cm steps.

Listening Position examples as follows:

Example 1: Front Left Seat

Adjust the time correction level of the front left speaker to a high value and the rear right to zero or a low value.

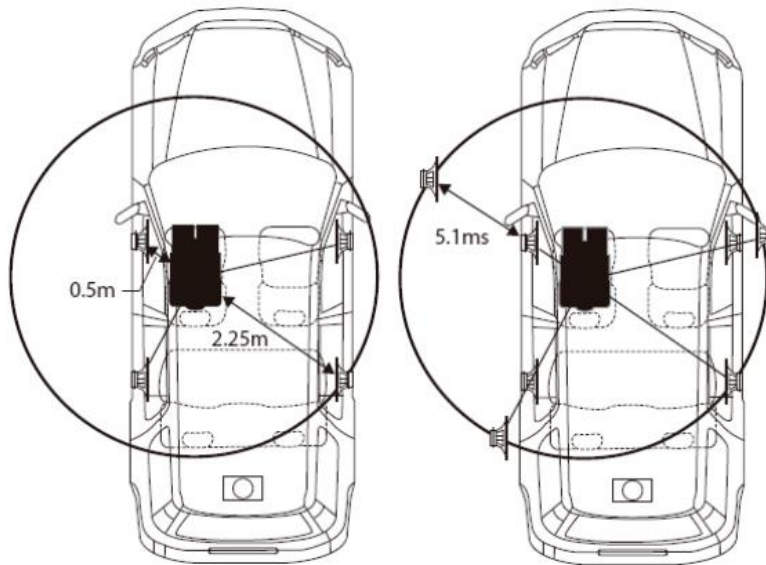

The sound is not balanced because the distance between the listening position and the various speakers is different. The difference in distance between the front left speaker and the rear right speaker is 1.75 m (68-7/8"). Here we calculate the time correction value for the front left speaker in the above diagram.

Conditions:

Farthest Speaker – listening position: 2.25 m (88-9/16")

Front left speaker – listening position: 0.5 m (19-11/16")

Calculation: $L = 2.25 \text{ m} - 0.5 \text{ m} = 1.75 \text{ m}$ (68-7/8")

Time correction = $1.75 \div 343 \times 1,000 = 5.1 \text{ (ms)}$

* *Speed of sound: 343 m/s (765 mph) at 20°C*

In other words, giving the front left speaker a time correction value of 5.1 ms makes it seem as if its distance from the listener is the same as the distance to the farthest speaker. Time correction eliminates the differences in the time required for the sound to reach the listening position. The time of the front left speaker is corrected by 5.1 ms so that its sound reaches the listening position at the same time as the sound of other speakers.

Example 2: All Seats

Adjust the time correction level of each speaker to almost the same level.

- 1 Sit in the listening position (driver's seat, etc.) and measure the distance (in meters) between your head and the various speakers.
- 2 Calculate the difference between the distance correction value to the farthest speaker and the other speakers.

$$L = (\text{distance to farthest speaker}) - (\text{distance to other speakers})$$

These values are the time correction values for the different speakers. Set these values to make each sound reach the listening position at the same time as the sound of other speakers.

Time Correction Value List

Delay Number	Time Difference (ms)	Distance (cm)	Distance (inch)
0	0.0	0.0	0.0
1	0.1	3.4	1.3
2	0.2	6.8	2.7
3	0.3	10.2	4.0
4	0.4	13.6	5.4
5	0.5	17.0	6.7
6	0.6	20.4	8.0

7	0.7	23.8	9.4
8	0.8	27.2	10.7
9	0.9	30.6	12.1
10	1.0	34.0	13.4
11	1.1	37.4	14.7
12	1.2	40.8	16.1
13	1.3	44.2	17.4
14	1.4	47.6	18.8
15	1.5	51.0	20.1
16	1.6	54.4	21.4
17	1.7	57.8	22.8
18	1.8	61.2	24.1
19	1.9	64.6	25.5
20	2.0	68.0	26.8
21	2.1	71.4	28.1
22	2.2	74.8	29.5
23	2.3	78.2	30.8
24	2.4	81.6	32.2
25	2.5	85.0	33.5
26	2.6	88.4	34.8
27	2.7	91.8	36.2
28	2.8	95.2	37.5
29	2.9	98.6	38.9
30	3.0	102.0	40.2
31	3.1	105.4	41.5
32	3.2	108.8	42.9
33	3.3	112.2	44.2
34	3.4	115.6	45.6
35	3.5	119.0	46.9
36	3.6	122.4	48.2
37	3.7	125.8	49.6

Delay Number	Time Difference (ms)	Distance (cm)	Distance (inch)
38	3.8	129.2	50.9
39	3.9	132.6	52.3
40	4.0	136.0	53.6
41	4.1	139.4	54.9
42	4.2	142.8	56.3
43	4.3	146.2	57.6
44	4.4	149.6	59.0
45	4.5	153.0	60.3
46	4.6	156.4	61.6
47	4.7	159.8	63.0
48	4.8	163.2	64.3
49	4.9	166.6	65.7
50	5.0	170.0	67.0
51	5.1	173.4	68.3
52	5.2	176.8	69.7
53	5.3	180.2	71.0
54	5.4	183.6	72.4
55	5.5	187.0	73.7
56	5.6	190.4	75.0
57	5.7	193.8	76.4
58	5.8	197.2	77.7
59	5.9	200.6	79.1
60	6.0	204.0	80.4
61	6.1	207.4	81.7
62	6.2	210.8	83.1
63	6.3	214.2	84.4
64	6.4	217.6	85.8
65	6.5	221.0	87.1
66	6.6	224.4	88.4
67	6.7	227.8	89.8
68	6.8	231.2	91.1
69	6.9	234.6	92.5
70	7.0	238.0	93.8
71	7.1	241.4	95.1
72	7.2	244.8	96.5
73	7.3	248.2	97.8
74	7.4	251.6	99.2
75	7.5	255.0	100.5

Delay Number	Time Difference (ms)	Distance (cm)	Distance (inch)
76	7.6	258.4	101.8
77	7.7	261.8	103.2
78	7.8	265.2	104.5
79	7.9	268.6	105.9
80	8.0	272.0	107.2
81	8.1	275.4	108.5
82	8.2	278.8	109.9
83	8.3	282.2	111.2
84	8.4	285.6	112.6
85	8.5	289.0	113.9
86	8.6	292.4	115.2
87	8.7	295.8	116.6
88	8.8	299.2	117.9
89	8.9	302.6	119.3
90	9.0	306.0	120.6
91	9.1	309.4	121.9
92	9.2	312.8	123.3
93	9.3	316.2	124.6
94	9.4	319.6	126.0
95	9.5	323.0	127.3
96	9.6	326.4	128.6
97	9.7	329.8	130.0
98	9.8	333.2	131.3
99	9.9	336.6	132.7

About the Crossover

Crossover (X-OVER):

This unit is equipped with an active crossover. The crossover limits the frequencies delivered to the outputs. Each channel is controlled independently. Thus, each speaker pair can be driven by the frequencies for which they have been optimally designed.

The crossover adjusts the HPF (high pass filter) or LPF (low pass filter) of each band, and also the slope (how fast the filter rolls off the highs or lows).

Adjustments should be made according to the reproduction characteristics of the speakers. Depending on the speakers, a passive network may not be necessary. If you are unsure about this point, please consult your authorized Alpine dealer.

Active 2-way mode

	Cut-off frequency (1/3 octave steps)		Slope		Level
	HPF	LPF	HPF	LPF	
Low range speaker	----	20Hz - 200Hz	----	FLAT, 6, 12 dB/oct.	0 to -12 dB
Rear high range speaker	20Hz - 200Hz	----	FLAT, 6, 12 dB/oct.	----	0 to -12 dB
Front high range speaker	20Hz - 200Hz	----	FLAT, 6, 12 dB/oct.	----	0 to -12 dB

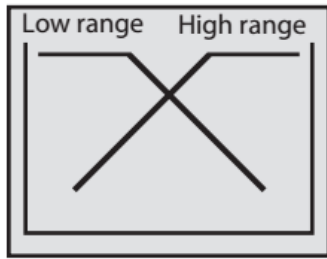

(Different from actual display)

Active 3-way mode

	Cut-off frequency (1/3 octave steps)		Slope		Level
	HPF	LPF	HPF	LPF	
Low range speaker	----	20Hz - 800Hz	----	FLAT, 6, 12 dB/oct.	0 to -12 dB
Mid range speaker	20Hz - 800Hz	20Hz - 20kHz	FLAT, 6, 12 dB/oct.	FLAT, 6, 12 dB/oct.	0 to -12 dB
High range speaker	1kHz - 20kHz	----	6, 12 dB/oct.	----	0 to -12 dB

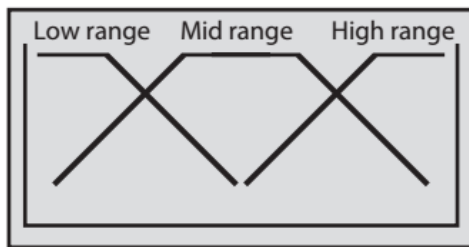

(Different from actual display)

**Level adjusting
(0 to -12 dB)**

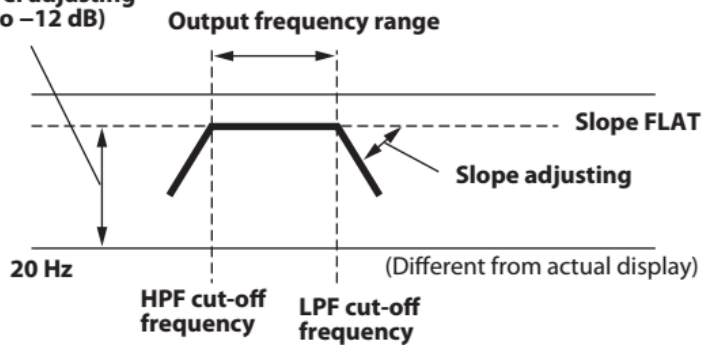

Notes

- *HPF (high pass filter): Cuts the lower frequencies and allows the higher frequencies to pass.*
- *LPF (low pass filter): Cuts the higher frequencies and allows the lower frequencies to pass.*
- *Slope: The level change (in dB) for a frequency change of one octave.*
- *The higher the slope value, the steeper the slope becomes.*
- *Adjust the slope to FLAT to bypass the HP or LP filters.*
- *Do not use a tweeter without the HPF on or set to a low frequency, as it may cause damage to the speaker due to the low frequency content.*
- *You cannot adjust the crossover frequency higher than the HPF or lower than the LPF.*
- *Adjustment should be made according to the recommended crossover frequency of the connected speakers. Determine the recommended crossover frequency of the speakers. Adjusting to a frequency range outside that recommended may cause damage to the speakers.*

For the recommended crossover frequencies of Alpine speakers, refer to the respective Owner's Manual.

Crossover Setup

- 1 In the Normal mode, press and hold **▶▶**, **▶/||**, **◀◀** successively for at least 2 seconds.
- 2 Turn the Rotary encoder to select active 3-way mode or active 2-way mode.
- 3 Press **▶/||** to determine the selected content by following the screen prompts.
When the setting finishes, the system will restart automatically.

About active crossover mode

Frequency range is divided between highs for front/rear speakers and lows for the Subwoofer.

Active 2-way mode

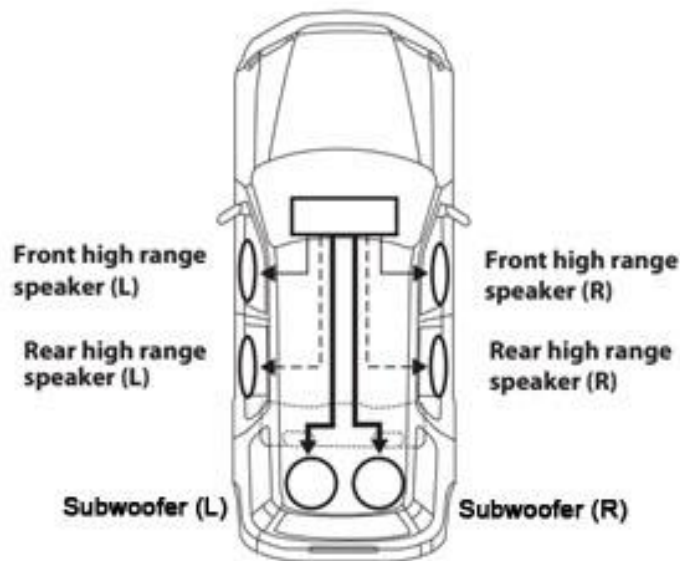

Frequency range is divided between highs/mediums for front speakers and lows for low range speakers.

Active 3-way mode

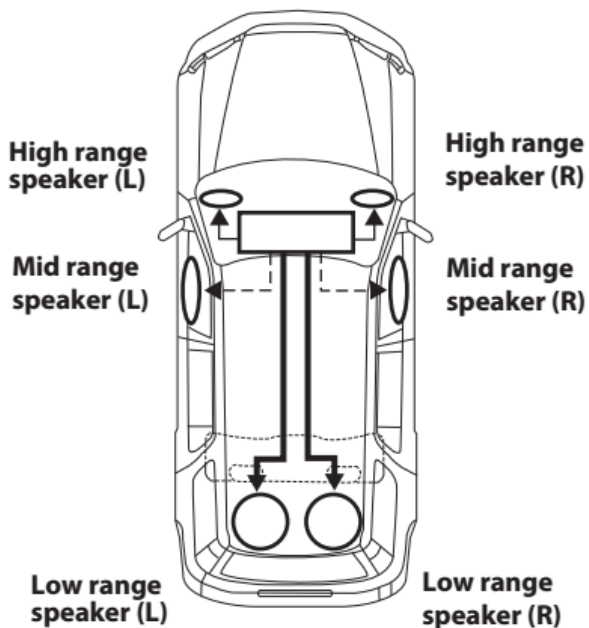

Output of this unit:

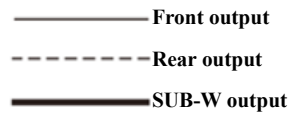

Note

- You cannot adjust the front/rear output balance when set to active 3-way mode.

This unit's sound tuning is programmable from a connected Smartphone. It is also possible to download specific parameters for certain vehicles from Alpine TuneIt database stored in the Cloud. Using the Alpine TuneIt App, customized parameters can also be uploaded for others to use. The installed Alpine TuneIt App should be launched on the Smartphone before connection to the head unit.

About downloading Alpine TuneIt App, please consult your Alpine dealer.

Before these operations, set TuneIt Connecting Device to USB or Bluetooth depending on the connected Smartphone. For details, see "[Alpine TuneIt Connecting Device](#)".

Note

- The application programme and related specifications and data may be deleted or terminated without notice.
- Some Alpine TuneIt App functions may not be available if the Smartphone is not in a service area or receives no signal.

Adjusting the sound via the Smartphone

After setting the above procedure, you can adjust the unit's sound function on the Smartphone.

- 1 Make sure the unit is powered on.
- 2 Launch the Alpine TuneIt App on the Smartphone. Adjust the unit's sound accordingly on the Smartphone.

Note

- The volume level and EQ PRESETS cannot be adjusted via the Smartphone.
- The setting cannot be done on both the Smartphone and this unit at the same time.
- When the unit is powered off or during a call, sound setting cannot be done via the Smartphone.
- This function may not be available depending on the paired Smartphone.
- Please obey all local traffic laws while using this function.

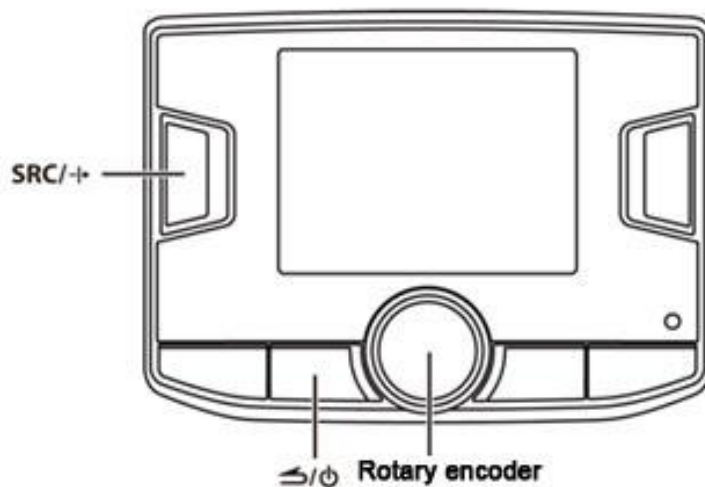

Setup

You can flexibly set the unit to suit your own preference and usage. From the SETUP menu, you can modify General Setup, Display Setup, etc.

Use steps 1 to 5 to select any SETUP mode to adjust. For details on the selected SETUP item, see the applicable sections below.

- 1 Press and hold the Rotary encoder for at least 2 seconds to activate the SETUP mode.
- 2 Turn the Rotary encoder to select the desired item, and then press the Rotary encoder.
Sound*¹ ↔ Normal ↔ Bluetooth*²

*1 Refer to “*Audio Setup*”.
*2 Refer to “*Bluetooth Setup*”.
- 3 Turn the Rotary encoder to select the setting item, and then press the Rotary encoder.
Language Setting ↔ Dimmer Control ↔ TuneIt Connecting Device ↔ Demonstration Mode ↔ About ↔ Restore Factory Settings
- 4 Turn the Rotary encoder to change the setting, and then press the Rotary encoder.
- 5 Press **SRC/→** to disable the SETUP mode.

Note

- Pressing **↶** returns to the previous SETUP mode.

Normal setting

Select Normal from the SETUP menu in Step 2.

Setting Display Language

You may choose Chinese or English display as you like.

- **Setting item:** Language Setting
Setting contents: Simplified Chinese (Initial setting) / English

Dimmer Control

Set the Dimmer control to AUTO to decrease the illumination brightness of the unit with the head lights of the vehicle ON.

- **Setting item:** Dimmer Control
Setting contents:
AUTO (Initial setting) / MANUAL

Setting the Dimmer Level

When setting the Dimmer Level, three levels can be selected. The brightness is lowest at the highest level (Level 3) when the headlight is turned ON.

- **Setting item:** Dimmer Level
Setting contents:
Level 1 (Initial setting) / Level 2 / Level 3

Alpine TuneIt Connecting Device

Set TuneIt Connecting Device to USB when an iPhone is connected, or set it to Bluetooth when an Android smart phone is paired.

- **Setting item:** TuneIt Connecting Device
Setting contents:
OFF / USB (Initial setting) / Bluetooth
OFF:
No smart phone is connected.
USB:

When an iPhone is connected the rear USB terminal of UTX-A09, use Alpine TuneIt App to adjust the unit's sound tuning parameters.

Bluetooth:

Set this item when an Android smart phone is paired with the unit through Bluetooth. Then, you can use Alpine TuneIt App to adjust the unit's sound tuning parameters.

Note

- *This function cannot be used at the time being. It will be provided in the future upgraded version.*
- *After the above setting is performed, turn the Ignition Switch to ACC OFF and then back to ACC ON.*
- *To enable this function, Alpine TuneIt App must be installed on the smart phone before connection. For details, consult your Alpine dealer or Alpine website.*
- *Only iPhone and some Android smart phones support this function.*

Demonstration

This unit has the screen demonstration function.

■ **Setting item:** DEMO MODE

Setting contents:

OFF (Initial setting) / ON

Note

- *To turn off the demonstration mode, set it to "OFF".*

Information about the Unit

Here, you can confirm the information such as BU version of the unit. Select "About" to review the following information.

BU Version/Gerda Version/Bluetooth Address/Name of the Unit

Restoring Factory Settings

After setting Restoring Factory Settings, all settings other than the debugged Dealer Setup mode will return to the factory defaults.

■ **Setting item:** Restoring Factory Settings

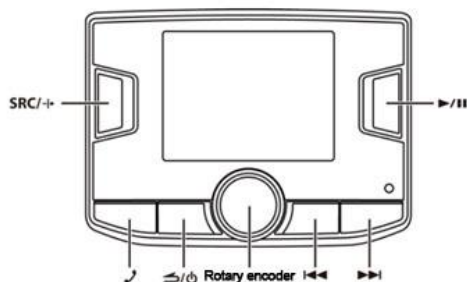

Setup before Using

About Bluetooth®

Bluetooth is a wireless technology allowing communication between a mobile device or personal computer over short distances. This enables a hands-free call or data transmission between Bluetooth compatible devices. Bluetooth transmission is available in the unlicensed 2.4 GHz spectrum if the distance between devices is within 10 meters. For details, refer to the Bluetooth Homepage (<http://www.bluetooth.com>).

Notes

- Depending on the Bluetooth version, a Bluetooth compatible device may not be able to communicate with this unit.
- Proper function of this unit with all Bluetooth compatible devices is not guaranteed. For handling of the BT compatible device, consult your ALPINE dealer or ALPINE website.
- Depending on the surroundings, Bluetooth wireless connection may be unstable.
- When you place a call or perform setup operations, be sure to stop your car in a safe place.
- Depending on the connected Bluetooth compatible device(s), the function may differ. Also refer to the Owner's Manual of the connected device(s).
- When you search for this unit using the Bluetooth compatible phone, the unit name is displayed as "UTX-A09".

Before Using Bluetooth Function

Before using the Bluetooth function, the following settings need to be made.

Set **Bluetooth Setup** to **ON** when you want to use **Hands-Free phone** or **BT Audio** function. Refer to "[Setting the Bluetooth Connection](#)".

Note

- Before using Bluetooth function, it must be paired with this unit. Refer to "[How to connect to a Bluetooth compatible device \(Pairing\)](#)".

How to connect to a Bluetooth compatible device (Pairing)

For details on the control from a Bluetooth compatible device, refer to the Owner's Manual of the Bluetooth compatible device.

- 1 Using your Bluetooth compatible device, select "UTX-A09" for pairing.

For Bluetooth compatible device with SSP (Secure Simple Pairing)

- 2-1 Turn the Rotary encoder when the pairing prompt appears on screen.
Press the  button if you want to refuse pairing.

For Bluetooth compatible device without SSP (Secure Simple Pairing)

- 2-2 Input the PIN code ("0000") in a Bluetooth compatible device.

Note

- The PIN code is fixed as "0000".

- 3 If the pairing was successful, "Connected" is displayed for a few seconds. The head unit then returns to its previous state.

Notes

- If the connection is unsuccessful, "Failed" is displayed.
- After a successful pairing, the two devices should re-pair automatically whenever the vehicle's ignition is turned ON. If the auto re-pairing fails, try to pair manually.
- Set "Visible Mode" to ON to enable this unit to be recognized by a BLUETOOTH compatible device. Refer to "[Setting the Visible Mode](#)".
- You can also manually pair the BLUETOOTH devices from this unit. For details, refer to "[Pairing a BLUETOOTH Device from the unit](#)".

Bluetooth SETUP

The following steps 1 to 5 are applicable to various Bluetooth functions. For details, refer to each individual function.

Note

- Set **Bluetooth SETUP** to **ON**, and then perform **Bluetooth SETUP** operation. Refer to "[Setting the Bluetooth Connection](#)".

- 1 Press and hold the Rotary encoder for at least 2 seconds to activate the SETUP mode.
- 2 Turn the Rotary encoder to select "BLUETOOTH", and then press the Rotary encoder.
The Bluetooth Setup mode is activated.
- 3 Turn the Rotary encoder to select the desired items, and then press the Rotary encoder.

BLUETOOTH:

Bluetooth Setup*1 ↔ Setting Bluetooth Device*2 ↔ Visual Mode*1/*2 ↔ Call Volume*2 ↔ Phone Book Synchronization*1/*2

*1 The items are not displayed during a phone call.

*2 The items are not displayed when the Bluetooth Setup is set to OFF. Refer to "[Setting the Bluetooth Connection](#)".

- 4 Turn the Rotary encoder to change the settings.
- 5 Press **SRC/→** to disable the Setup mode.

Note

- Press **↶** to return to the previous mode.

Setting the Bluetooth Connection

With BLUETOOTH technology, you can place a hands-free call by a BLUETOOTH-equipped mobile phone.

Audio information of a device such as BLUETOOTH compatible mobile phone and portable audio player is controllable/playable wirelessly from this unit.

■ Setting item: Bluetooth Setup

Setting contents:

OFF / ON (Initial setting)

OFF:

Disable the hands-free call function and Bluetooth audio function.

ON:

Select this item when you want to pair a Bluetooth compatible phone with this unit or use Bluetooth audio function.

Setting the Bluetooth Device

This unit can pair at most 3 Bluetooth compatible devices. Select one from the list of previously paired devices.

■ Setting item: Setting Bluetooth Device

- 1 Turn the Rotary encoder to select a Bluetooth compatible device you want to use (you want to change connection), and then press the Rotary encoder.
- 2 Turn the Rotary encoder to select the type of device (phone, Bluetooth Audio or both) you want to connect, and then press the Rotary encoder.
The status indicator of a successfully connected device (phone & Bluetooth Audio) lights up.

Notes

- Depending on the connected Smartphone, the battery charge and signal strength may be displayed on screen.
- If all 3 devices have been paired with the unit, a 4th device cannot be paired. If you want to pair another device, one of the previously paired devices at Position 1 to 3 should be deleted.

Pairing a BLUETOOTH Device from the unit

Searching can be performed on this unit when less than 3 devices are paired with it.

- 1 After entering Setting the Bluetooth Device screen, turn the Rotary encoder to select "No Device", and then press the Rotary encoder.
Press the **↶** button to stop searching.

Be sure this operation is performed on the Bluetooth device with Bluetooth ON.

- 2 The screen will display the searched Bluetooth device name. Turn the Rotary encoder to select a device, and press the Rotary encoder for Bluetooth pairing.
When the pairing is successful, "Connected" is displayed on screen.

Setting the Visible Mode

You can set whether this unit can be recognized by a BLUETOOTH compatible device. Normally set this to ON.

■ Setting item: Visible Mode

Setting contents:

OFF / ON (Initial setting)

OFF:

This unit cannot be searched from the mobile phone when making Bluetooth pairing.

ON:

This unit can be searched from the mobile phone when making Bluetooth pairing.

Setting the Volume of Phone Call

You can flexibly customize the volume of phone call to fit your preferences.

■ **Setting item:** Call Volume

■ **Setting sub-item:** Incoming Call Volume / Ring Tone Volume

Adjusting the Volume

You can emphasize or weaken the volume level of phone call and ring tone to fit your own preferences.

Setting contents: 1~11

Note

- Depending on the connected Smartphone, the battery charge and signal strength may be displayed on screen. The initial setting of Incoming Call Volume / Ring Tong Volume is 5.

Setting the Phone Book Update

You can update the phone book.

■ **Setting item:** Phone Book Synchronization

Setting contents:

OFF / ON (Initial setting)

OFF:

The phone book will not be synchronized to the unit. You cannot select a person from the unit to place a call. A number can be dialed from the mobile phone only.

ON:

The phone book will be synchronized to the unit. You can select a person from the unit to place a call.

Hands-free Phone Control

About the Hands-Free Phone

Hands-free calls are possible when using a HSP (Head Set Profile) and HFP (Hands-Free Profile) compatible mobile phone with this unit.

Notes

- Avoid performing a hands-free call in heavy traffic or on narrow or winding streets.
- Close the windows while calling to reduce background noise.
- If both calling parties are using hands-free devices, or the call is made at a noisy location, difficulty hearing the other person's voice is normal.
- Depending on telephone line conditions or certain mobile devices used, voices may sound unnatural.
- When using a microphone, speak as directly as you can into the microphone to pick up the best sound quality.
- Certain mobile phone features are dependent on the capabilities and settings of your service provider's network. Additionally, certain features may not be activated by your service provider, and/or the provider's network settings may limit the feature's functionality.

Always contact your service provider about feature availability and functionality.

All features, functionality, and other product specifications, as well as the information contained in the Owner's Manual are based upon the latest available information and are believed to be accurate at the time of printing.

Alpine reserves the right to change or modify any information or specifications without notice.

Answering a Call

Incoming calls are announced by the received call ring tone and a displayed message.

Press .

The call starts.

Note

- While calling, the source sound on the unit is muted. After calling, playback will resume.

Hanging up the Telephone

Press .

The call finishes.

Calling

Call History is recorded for the last dialed/received/missed calls (20 records for each). There are various ways of making calls based on the "Calling". The following steps 1 to 5 are common to the various ways of making these calls. For details, refer to each individual category for making calls.

1 Press .

The calling list is displayed.

2 Turn the Rotary encoder to select the outgoing mode.

Setting contents:

Dialed Call / Received Call / Missed Call / Phone Book

3 Press the Rotary encoder.

The outgoing mode is activated, and each mode list is displayed.

Note

- It may take some time for the list to be displayed. Also directly after connection, the list may not be brought up to date.

4 Turn the Rotary encoder to select a name or a telephone number from the list.

Note

- You can use Phone book alphabet search function to search a name or number from Phone Book. For details, refer to "Phone Book Alphabet (or Pinyin for Chinese version) Search Function".

5 Press .

The selected telephone number will be called.

If you select a name from Phone Book, press the Rotary encoder to confirm it. Then turn the Rotary encoder to choose the desired number and press  to place a call.

Note

- Press  to return to the previous mode.

Redialing a Number in Outgoing History

Previously dialed telephone numbers (at most 20 calling records) are stored in dialed calls history. You can redial a number by searching from dialed calls history.

 **Setting item:** Dialed Call

Dialing a Number in Incoming History

Telephone numbers from received calls (at most 20 calling records) are stored in the Received List. You can redial these numbers by searching here.

 **Setting item:** Received Call

Dialing a Number in Incoming Missed Call History

Telephone numbers for received calls that are missed (at most 20 calling records) are stored in the Missed List. You can redial these numbers by searching here.

 **Setting item:** Missed Call

Dialing a Number in the Phone Book

Up to 1,000 names (at most 4 telephone numbers for each name) are downloadable from a mobile phone. Dial a call by selecting a person from the phone book list.

Setting item: Phone Book

Note

- Before using the above-mentioned functions, be sure to enable the Phone Book Synchronization function.
- If the call history or phone book of the mobile phone is added or deleted while it is connected to the unit, the list displayed on the unit may not be brought up to date.

If it is not updated, you cannot correctly place a call.

Phone Book Alphabet (or Pinyin for Chinese version) Search Function

With the Phone Book Alphabet Search Function, you can rapidly search a desired name in the Phone Book.

On the Phone Book display screen, each time you press **◀◀** or **▶▶**, it will skip to a contact name beginning with the previous or next Alphabet (Pinyin).

For example: When the name "An**" is displayed, pressing **▶▶** will skip to a contact name beginning with Alphabet (Pinyin) B (e.g. Bai**).

Note

- It is useless to press **◀◀** at the beginning of Phone BOOK or press **▶▶** at the end of Phone Book.
- In Alphabet Search, if there is no contact name beginning with the adjacent Alphabet, it will skip to the previous or next effective contact name that can be searched.

Adjusting the volume when receiving a Call

While calling, you can adjust the volume.

Turn the Rotary encoder to adjust the volume.

Note

- You may need to increase volume from your regular audio listening source level. However, increasing the volume excessively may result in feedback. Feedback is directly related to the volume. Turning down the volume as low as acceptable will reduce it. Positioning the microphone in a direction away from the main car speakers (e.g. clipped on sun visor) may also reduce feedback at high volume.

Call Switching Operation

While making a call, this function allows you to activate the switching of audio between the mobile phone and the speakers in the car.

While calling, press **▶/||** to switch the call sound between the unit and the mobile phone.

Note

- Depending on the mobile phone, this operation may not be performed.

BLUETOOTH Audio Operation

Audio information of a BLUETOOTH compatible mobile phone, a portable player, etc. is controllable/playable wirelessly* from this unit.

* To play back audio, a mobile phone or a portable player conforming to A2DP (Advanced Audio Distribution Profile) and AVRCP (Audio/Video Remote Control Profile) is required.

Not all functions work with all devices.





Note

- Set "Bluetooth Setup" to ON when you want to use Bluetooth Audio function. Refer to "[Setting the BLUETOOTH Connection](#)".
- During a call, sound on the BLUETOOTH audio source is muted.
- If you operate the Hands-free phone (e.g. searching in the phone book) while using the Bluetooth Audio function, BLUETOOTH Audio playback may be affected.

Recalling the Bluetooth Audio Mode

Press **SRC/➔** to select the Bluetooth Audio mode.

Selecting the Desired Song

- 1 Press .
Return the beginning of the song being played back.
Press and hold  to skip backward.
- 2 Press .
Skip forward to the next song.
Press and hold  to skip forward.

Note

- This operation may differ depending on the connected device.
- The unit has independent memory function for volume adjustment of Bluetooth Audio source.

Repeat Play

- 1 Press .
The song is played back repeatedly.



- *1 Only a file is repeatedly played back.
- *2 All files in the current Group (Folder) are repeatedly played back.
- *3 All playable files in the Bluetooth device are repeatedly played back.
- *4 Repeat Play is turned off.

Note

- This function may be unavailable depending on the paired device.

Pausing

Press .

A playback stops. Touching again will resume a playback.

Searching for a desired song

Artist name, album name, etc. may be searched and displayed during playback or pause.

- 1 Press the Rotary encoder to activate the search mode.
- 2 Turn the Rotary encoder to select the desired Group (Folder), and then press the Rotary encoder.
- 3 Turn the Rotary encoder to select the desired album, folder, etc. within the selected Group (Folder), and then press the Rotary encoder.
- 4 Repeat step 3 if necessary until the desired song is found.

Notes

- Search mode may differ depending on the connected device.
- The pause mode may be canceled after the search.
- This function may be unavailable depending on the paired device.

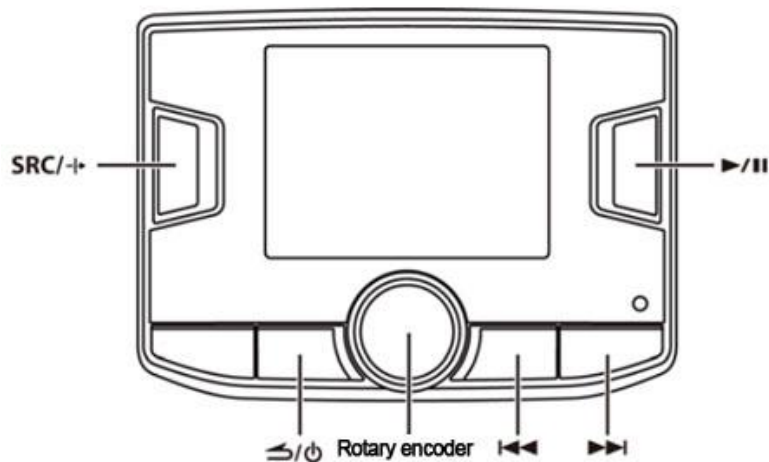

Connecting an iPod/iPhone

An iPod/iPhone can be connected to the rear USB terminal of this unit by using the Interface cable for iPod (supplied with iPod/iPhone).

Notes

- Only the rear USB terminal supports iPod/iPhone connection. Do not connect an iPod/iPhone to the front USB terminal of this unit.
- To guarantee normal operation of this unit, do not connect a mobile phone or other charging device to the front USB terminal when an iPod/iPhone is connected.
- Internet and telephone functions of the iPod touch or iPhone, etc can also be used while connected to this unit. However, using these functions will stop or pause the currently playing songs.
Stop using any application or telephone function, and then resume audio playback on the device used.

About iPod/iPhone models usable with this unit



- Confirmed devices specially made for iPod. Correct function of earlier versions cannot be guaranteed.
iPod touch (6th generation): Ver. 11.0.3
- Confirmed devices specially made for iPhone. Correct function of earlier versions cannot be guaranteed.
iPhone 7 Plus: Ver. 11.0.3
iPhone 7: Ver. 11.0.3
iPhone SE: Ver. 11.0.3
iPhone 6s Plus: Ver. 11.0.3
iPhone 6s: Ver. 11.0.3
iPhone 6s Plus: Ver. 11.0.3
iPhone 6: Ver. 11.0.3
iPhone 5s: Ver. 11.0.3
iPhone 5c: Ver. 11.3.3
iPhone 5: Ver. 11.3.3
- This unit does not support video playback from iPod/iPhone.

Playback

- 1 Press **SRC/↔** to switch to the iPod mode.
- 2 Press **◀◀** or **▶▶** to select the content you want to play.
Pressing and holding **◀◀** or **▶▶** will skip backward or forward.
- 3 To pause playback, press **▶/||**.

Pressing  again will resume playback.

Note

- An episode may have several chapters. The chapter can be changed by pressing  or .

Searching for a desired Song

An iPod/iPhone can contain many songs. This unit uses multiple methods to simplify the process of searching desired content.

As shown below, each music category has its own individual hierarchy. Select a music category from the table below to narrow the scope of search.

Hierarchy 1	Hierarchy 2	Hierarchy 3	Hierarchy 4
Playlist	Song	---	---
Artist	Album	Song	---
Album	Song	---	---
Song	---	---	---
Genre	Artist	Album	Song
Composer	Album	Song	---
Audiobook	---	---	---
Podcast	Episode	---	---
iTunes Radio	---	---	---

For example:

Searching by Artist name.

The following example explains how an Artist search is performed. Another search mode can be used for the same operation, though the hierarchy differs.

- 1 Press the Rotary encoder to activate the search selection mode.
- 2 Turn the Rotary encoder to select the Artist search mode, and then press the Rotary encoder.
Playlist ↔ Artist ↔ Album ↔ Song ↔ Genre ↔ Composer ↔ Audiobook ↔ Podcast ↔ iTunes Radio
- 3 Turn the Rotary encoder to select the desired Artist, and then press the Rotary encoder.
- 4 Turn the Rotary encoder to select the desired Album, and then press the Rotary encoder.
- 5 Turn the Rotary encoder to select the desired Song, and then press the Rotary encoder.
The selected song is played back.

Note

- In the search mode, pressing  will return to the previous mode.

In Case of Difficulty

If you encounter a problem, please turn the power off, then on again. If the unit is still not functioning normally, please review the items in the following checklist. This guide will help you isolate the problem if the unit is at fault. Otherwise, make sure the rest of your system is properly connected or consult your authorized Alpine dealer.

Basic

No function or display.

- Vehicle's ignition is off.
 - If connected following instructions, the unit will not operate with the vehicle's ignition off.
- Improper power lead (Red) and battery lead (Yellow) connections.
 - Check power lead and battery lead connections.
- Blown fuse.
 - Check the fuse of the unit; replace with a fuse of proper specification if necessary.
- Internal micro-computer malfunctioned due to interference noise etc.
 - Press the RESET switch with a ballpoint pen or other pointed article.

Radio

Unable to receive stations.

- No antenna or cable disconnected.
 - Make sure the antenna is properly connected; replace the antenna or cable if necessary.

Unable to tune stations in the seek mode.

- You are in a weak signal area.
 - Make sure the tuner is in the AUTO mode.
- If the area you are in is a primary signal area, the antenna may not be grounded and connected properly.
 - Check your antenna connections; make sure the antenna is properly grounded at its mounting location.
- The antenna may not be of proper length.
 - Make sure the antenna is fully extended; if broken, replace the antenna with a new one.

Broadcast is noisy.

- The antenna is not of proper length.
 - Extend the antenna fully; replace it if it is broken.
- The antenna is poorly grounded.
 - Make sure the antenna is grounded properly at its mounting location.

MP3/WMA/AAC/WAV/FLAC/APE

MP3, WMA, AAC, WAV, FLAC or APE cannot be played back.

- Writing error occurs. The MP3/WMA/AAC/WAV/FLAC/APE format is not compatible.
 - Make sure the MP3/WMA/AAC/WAV/FLAC/APE has been written in a supported format. Refer to "[About MP3/WMA/AAC/WAV/FLAC/APE](#)", then rewrite them in the format supported by this device.

Audio

The sound is not output from the speakers.

- Unit has no output signal of the internal amplifier.
 - The internal amplifier is switched to "ON" (refer to "[Connecting to an External Amplifier](#)").

iPod

iPod does not play or no sound is output.

- The iPod has not been recognized.
 - Reset this unit and the iPod. Refer to "[Initial System Startup](#)". To reset the iPod, refer to the Owner's Manual of the iPod.

Indication for USB Memory/MTP

ERROR

- Communication error or boot error, etc.
 - You can solve the problem by turning ACC off/on.
-

Over-current

- The USB device encounters abnormal current.
 - You can solve the problem by turning ACC off/on.
-

Unsupported

- A USB device not supported by this unit is connected.
 - Connect a USB device supported by this unit.
 - An iPod/iPhone not supported by this unit is connected to any USB terminal.
 - Connect a supported iPod/iPhone to the rear USB terminal of this unit only.
-

No Response

- The USB/MTP device gives no response.
 - Remove the USB/MTP and plug in again.
-

USB Hub Unsupported

- This indication appears when a USB hub is connected.
 - Do not connect a hub to the unit.
-

Plug in USB

- No USB Memory/MTP is connected.
 - Make sure the USB Memory/MTP is correctly connected, and the cable is not bent excessively.
-

No Song

- No song (file) is stored in the USB Memory/MTP.
 - Connect the USB Memory in which songs (files) are stored.
-

Unsupported

- A file not supported by this unit is used.
 - Use the files supported by this unit.
-

Protect

- A copy-protected WMA file was played back.

- You can only play back non-copy-protected files.

Indication for iPod Mode

No iPod

- The iPod/iPhone is not connected.
 - Make sure the iPod/iPhone is correctly connected (refer to “[Connections](#)”).
Make sure the cable is not bent excessively.

No Song

- There are no songs in the iPod/iPhone.
 - Download songs to the iPod/iPhone, and connect to this unit.

ERROR

- Communication error or boot error, etc.
 - You can solve the problem by switching the source, turning ACC off/on, or turning power off/on.

Version Unsupported

- The iPod/iPhone version is too low.
 - Update the iPod/iPhone version.

Authentication Error

- The iPod/iPhone authentication fails.
 - Remove the iPod/iPhone and plug in again. Replace the device if playback still cannot be performed.

Connect iPhone/iPod to the Other USB Terminal

- The iPod/iPhone is connected to the front USB terminal of this unit.
 - Connect iPod/iPhone to the rear USB terminal only as the front USB terminal does not support iPod/iPhone connection.

BLUETOOTH Mode

No Unit

- The Bluetooth device is not connected.
 - Connect the Bluetooth device.
-

No Song

- There are no songs in the Bluetooth device.
 - Download songs to the Bluetooth device.

Specifications

FM TUNER SECTION

Tuning Range	87.5~108.0 MHz
Mono Usable Sensitivity	15.8 dBf (1.7 μ V/75 ohms S/N: 30 dB)
Signal-to-Noise Ratio	60 dB

AM TUNER SECTION

Tuning Range	531~1602 kHz
Sensitivity	32 μ V (S/N: 20 dB)
Signal-to-Noise Ratio	50 dB

USB SECTION

USB requirement	USB 2.0
Max. Power Consumption (rear USB)	1A
File System	FAT 16/32, exFAT
Signal-to-Noise Ratio	95 dB
Max. number of songs that can be played back (Total number of songs in front and rear USB)	10,000
MP3 Decoding	MPEG AUDIO Layer-3
WMA Decoding	Windows Media™ Audio
AAC Decoding	AAC-LC format ".m4a" file
WAV Decoding	Waveform sound file
FLAC Decoding	Free Lossless Audio Codec
APE Decoding	Monkey's audio

BLUETOOTH SECTION

BLUETOOTH version	4.0
-------------------	-----

GENERAL

Power Requirement	14.4 V DC (11-16 V allowed)
Power Output	22 W \times 4 (1 kHz, 5% THD, 4 Ω load, 2ch test)
Bass	\pm 9.1 dB at 100 Hz
Treble	\pm 9.1 dB at 10 kHz
Weight	0.8 kg

HEAD UNIT SIZE

Width	178 mm
Height	50 mm
Depth	146 mm

CONTROLLER SIZE

Width	95 mm
Height	69 mm
Depth	20 mm

Note • Due to continuous product improvement, specifications and design are subject to change without notice.

Installation and Connections

Before installing or connecting this unit, please read the instructions below and refer to “[Operating Instructions](#)” to guarantee correct use.

WARNING

MAKE THE CORRECT CONNECTIONS.

Failure to make the proper connections may result in fire or product damage.

USE ONLY IN CARS WITH A 12 VOLT NEGATIVE GROUND.

(Check with your dealer if you are not sure.) Failure to do so may result in fire, etc.

BEFORE WIRING, DISCONNECT THE CABLE FROM THE NEGATIVE BATTERY TERMINAL.

Failure to do so may result in electric shock or injury due to electrical shorts.

DO NOT SPLICE INTO ELECTRICAL CABLES.

Never cut away cable insulation to supply power to other equipment. Doing so will exceed the current carrying capacity of the wire and result in fire or electric shock

DO NOT DAMAGE PIPE OR WIRING WHEN DRILLING HOLES.

When drilling holes in the chassis for installation, take precautions so as not to contact, damage, or obstruct pipes, fuel lines, tanks or electrical wiring. Failure to take such precautions may result in fire.

DO NOT USE BOLTS OR NUTS IN THE BRAKE OR STEERING SYSTEMS TO MAKE GROUND CONNECTIONS.

Bolts or nuts used for the brake or steering systems (or any other safety-related system) or tanks should NEVER be used for installations or ground connections. Using such parts could disable control of the vehicle or cause fire etc.

KEEP SMALL OBJECTS SUCH AS BATTERIES OUT OF THE REACH OF CHILDREN.

Swallowing them may result in serious injury. If swallowed, consult a physician immediately.

DO NOT INSTALL IN LOCATIONS WHICH MIGHT HINDER VEHICLE OPERATION, SUCH AS THE STEERING WHEEL OR SHIFT LEVER.

Doing so may obstruct forward vision or hamper movement etc. and result in serious accident.

DO NOT ALLOW CABLES TO BECOME ENTANGLED WITH SURROUNDING OBJECTS.

Arrange wiring and cables in compliance with the Manual to prevent obstructions when driving. Cables or wiring that obstruct or hang up in places such as the steering wheel, shift lever, brake pedals, etc. can be extremely hazardous.

CAUTION

DO NOT INSTALL IN LOCATIONS SUBJECT TO DIRECT SUNLIGHT.

Prolonged exposure to high temperature and direct sunlight may damage the screen.

HAVE THE WIRING AND INSTALLATION DONE BY EXPERTS.

The wiring and installation of this unit requires special technical skill and experience. To ensure safety, always contact the dealer where you purchased this product to have the work done.

USE SPECIFIED ACCESSORY PARTS AND INSTALL THEM SECURELY.

Be sure to use only the specified accessory parts. Use of other than designated parts may damage this unit internally or may not securely install the unit in place. This may cause parts to become loose resulting in hazards or product failure.

ARRANGE THE WIRING SO IT IS NOT CRIMPED OR PINCHED BY A SHARP METAL EDGE.

Route the cables and wiring away from moving parts (like the seat rails) or sharp or pointed edges. This will prevent crimping and damage to the wiring. If wiring passes through a hole in metal, use a rubber grommet to prevent the wire's insulation from being cut by the metal edge of the hole.

DO NOT INSTALL IN LOCATIONS WITH HIGH MOISTURE OR DUST.

Avoid installing the unit in locations with high incidence of moisture or dust. Moisture or dust that penetrates into this unit may result in product failure.

 **PRECAUTIONS**

- Be sure to disconnect the cable from the (-) battery post before installing your UTX-A09. This will reduce any chance of damage to the unit in case of a short circuit.
- Be sure to connect the color coded leads according to the diagram. Incorrect connections may result in malfunction of the unit or damage to the vehicle's electrical system.
- When making connections to the vehicle's electrical system, be aware of the factory installed components (e.g. on-board computer). Do not tap into these leads to provide power for this unit. When connecting UTX-A09 to the fuse box, make sure the fuse for the intended circuit of UTX-A09 has the appropriate amperage. Failure to do so may result in damage to the unit and/or the vehicle. When in doubt, consult your Alpine dealer.
- UTX-A09 uses female RCA-type jacks for connection to other units (e.g. amplifier) having RCA connectors. You may need an adaptor to connect other units. If so, please contact your authorized Alpine dealer for assistance.
- Be sure to connect the speaker (-) leads to the speaker (-) terminal. Never connect left and right channel speaker cables to each other or to the vehicle body.

Installation

Installing the Head Unit

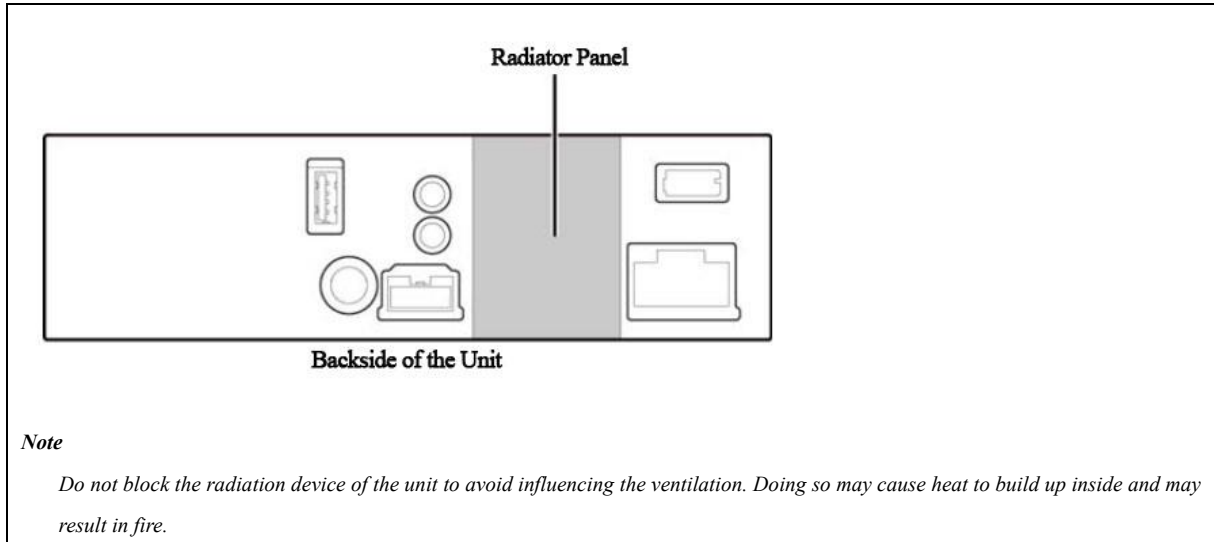

For details about the unit installation, please consult your authorized Alpine dealer.

Installing the Controller

Preparation

1 Check the accessories.

① Controller cable (2.5 m)



② Controller tray (used for reverse mold installation)

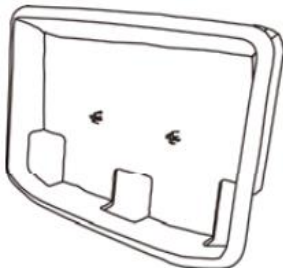

③ Controller bracket

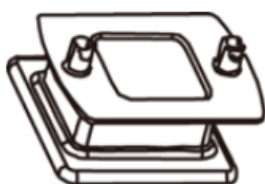

④ Adhesive tape (x2)

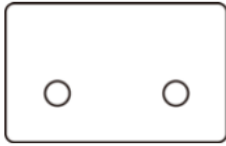

Used for bracket (reverse mold) installation or direct installation on the dashboard.

- ⑤ Light shield (used for installation with bracket)



Precautions concerning the Controller Installation

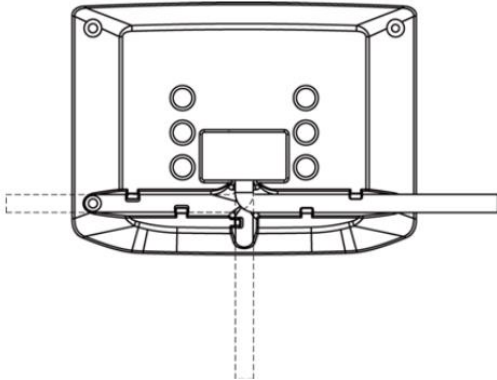

- 1 Adjust the direction of controller cable.
As shown in the above diagram, there are 3 directions optional for backside controller cable.
Select a proper cable direction to fit your vehicle.
- 2 Confirm the location hole (only for bracket installation)
When using the bracket to install the controller, you can adjust the height of controller by selecting the location hole on backside of the controller.

Using Adhesive Tape for Installation

- 1 Set the installation location.
 - Check whether the supplied cable is long enough. Install this unit at a location free from water.
Do not install the unit or wiring at the locations that hinder driving or airbag.
- 1 Affix the adhesive tape ④ onto backside of the controller. Be careful to align with holes in the second row on the casing.

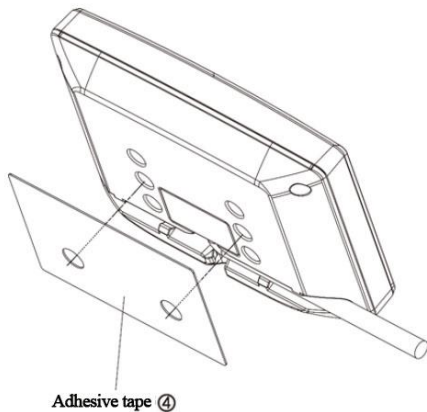

- 2 Attach the controller onto the console or dashboard, etc.

Using the Controller Bracket for Installation

- Set the installation location.
 - Check whether the supplied cable is long enough. Install this unit at a location free from water.
Do not install the unit or wiring at the locations that hinder driving or airbag.
 - Console or dashboard, etc
 - * Before installation, remove the assembly on which this product will be installed.*
- Attach the light shield ⑤ onto backside of the controller. Align with the two holes.

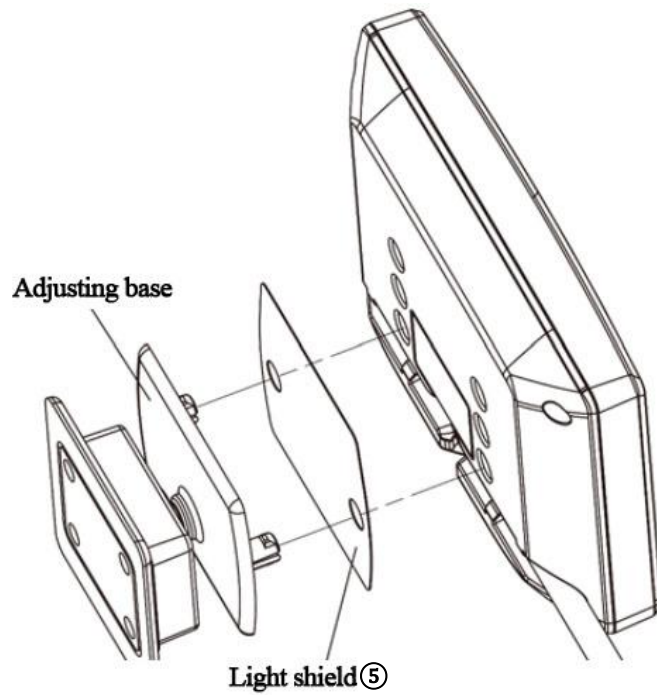

- Align the locking posts on the adjusting base of bracket ③ with the mounting holes on the controller, and press the base until it is secured.
- Then affix the bracket onto the console or dashboard, etc.

Using the Tray for Reverse Mold Installation

About reverse mold installation, consult your authorized Alpine dealer.

Here, only how to install the controller onto the tray is introduced.

- 1 Affix the Adhesive tape ④ onto the inner surface of the controller tray. Be careful to align the holes on the Adhesive tape with the location pillars on the tray. Then remove the release liner on the Adhesive tape.

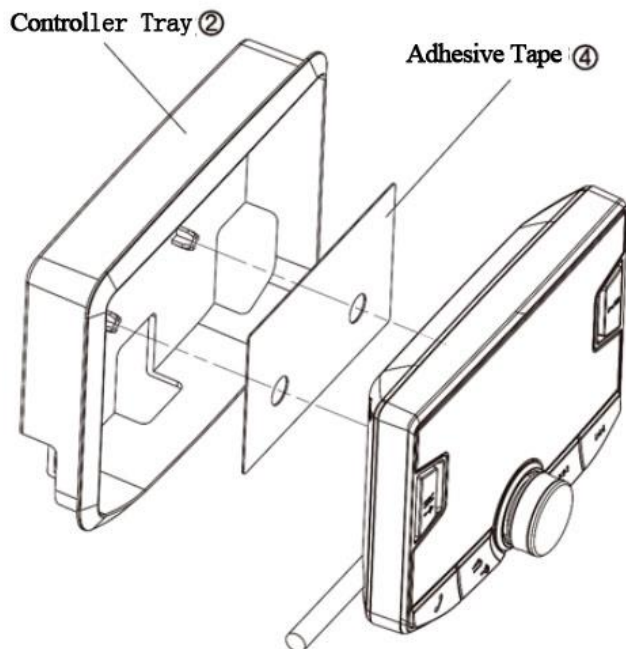

- 2 Align and press the controller securely into the tray.

CAUTION

Be sure the controller is securely fixed. If not, the controller may fall off while driving.

iPod/iPhone Connection (sold separately)

Connect an iPod/iPhone to the rear USB terminal of the unit.

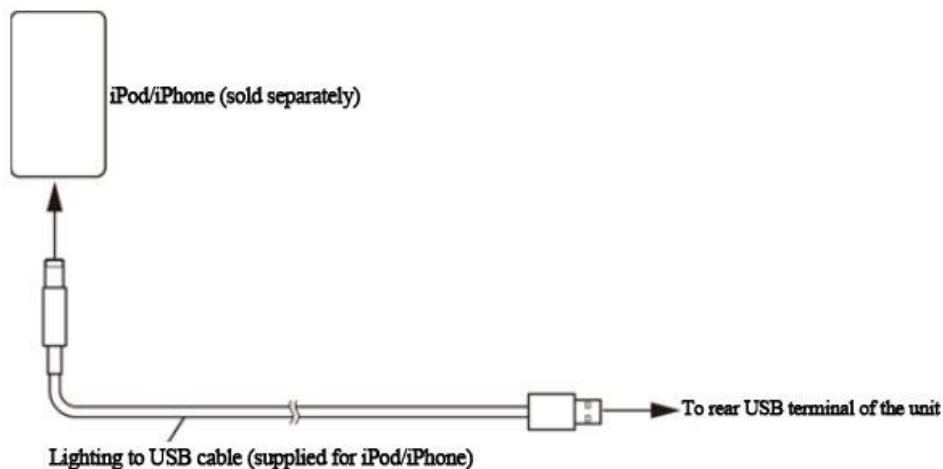

Note

- Only the unit compatible iPod/iPhone can be connected to the rear USB terminal. The front USB terminal does not support connection with iPod/iPhone.
- Do not connect a mobile phone or other charging device to the front USB terminal when an iPod/iPhone is connected. If you do so, normal performance of the unit cannot be guaranteed.

- Confirm whether the connected iPod/iPhone is supported by the unit if there is no sound output from it or the iPod/iPhone is not recognized after connection.
- Do not leave an iPod/iPhone inside the vehicle for a prolonged period. Heat and moisture may damage the iPod/iPhone, so that it may not be able to play.

USB Memory/MTP (Mobile Phone) Connection (sold separately)

This unit has front and rear USB terminals. You can connect a USB/MTP (mobile phone) to either terminal or both terminals. But it is not allowed to connect two MTP (mobile phone) or other charging devices concurrently.

You need to use the supplied USB cable when connecting to the rear USB terminal.

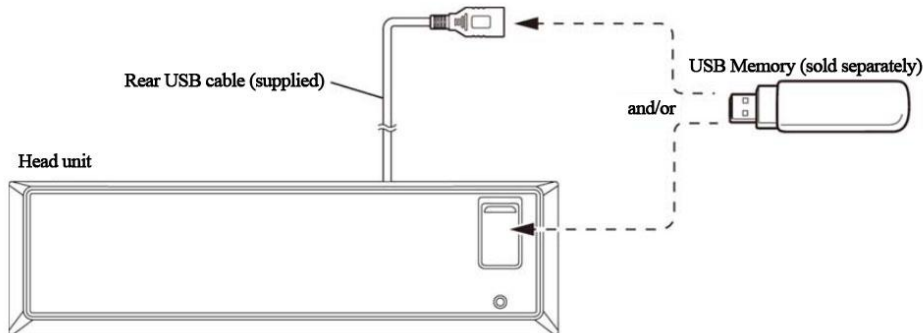

Note

- Pull out USB Memory squarely from the USB cable.
- Remove the USB Memory and reconnect it if there is no sound output from it or the USB Memory is not recognized after connection.
- Keep the USB cable away from other cables.

Mounting the Microphone

For the sake of safety, mount the microphone at the following locations.

- At a stable and secure location.
- At a location that does not inhibit safely driving the vehicle.
- Mount the microphone at a location where the driver's voice can easily be picked up.

Choose a location for the microphone that can easily pick up the driver's voice. Requiring the driver to move towards the microphone for audibility causes a distraction that could be dangerous.

Using the Rear AUX Input Connector

Connect the audio output terminal of the vehicle's sound system directly to the AUX IN terminal behind the unit. Adaptive cable (RCA extension cable or standard RCA cable to 3.5ø mini phono plug) should be purchased separately.

Pressing **SRC/➔**, you can select AUX mode to listen to the music or navigation prompts played by the vehicle's sound system.

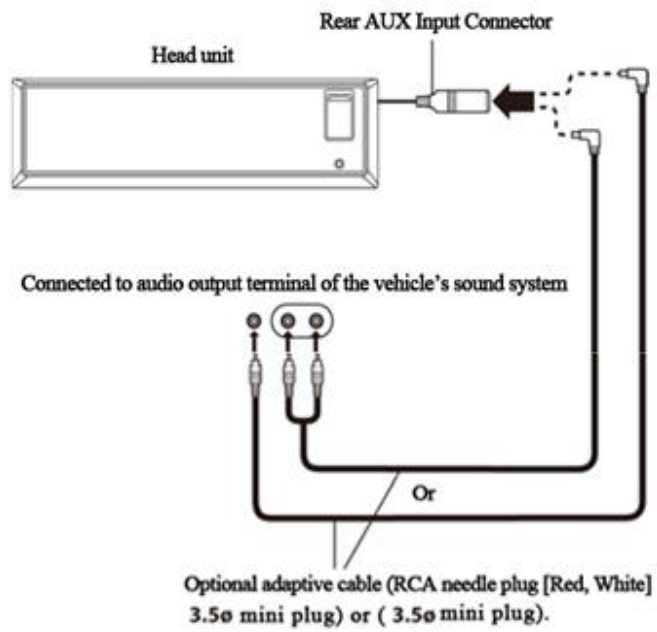

Note

- Press the **SRC/→** button for prolonged time to select *AUX Mix mode* if you do not want to miss the vehicle's navigation prompts while enjoying the music played by this unit. For details, refer to "[Setting the AUX Mix Mode](#)".

Connections

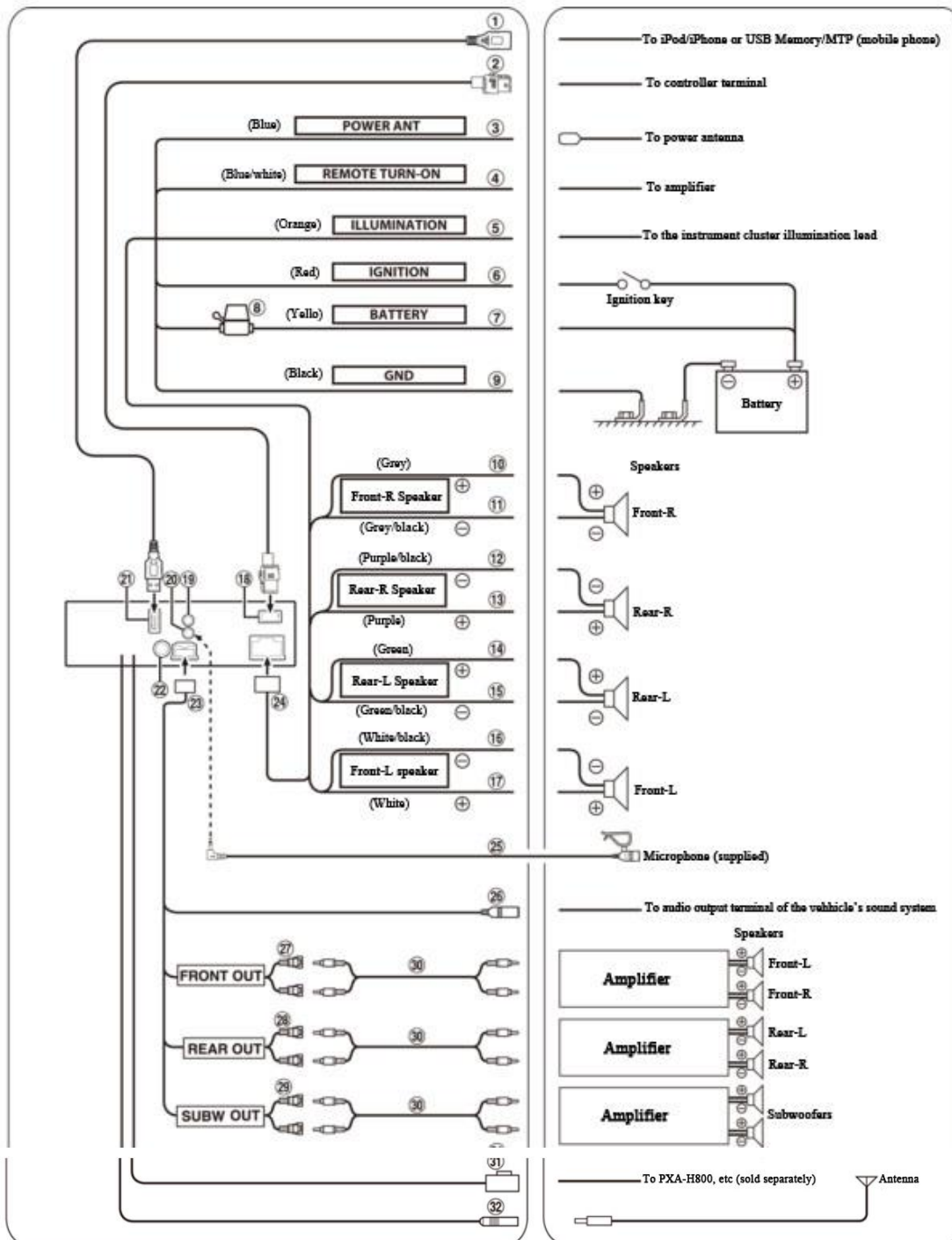

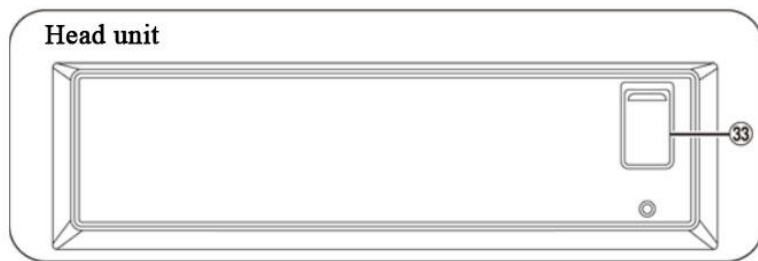

① Rear USB Cable (Supplied)

Connect it to USB Memory/MTP (mobile phone) or iPod/iPhone. Use Lightning to USB cable if an iPod/iPhone is connected.

Notes

- Please use the supplied USB cable. Normal performance cannot be guaranteed if a USB cable other than the supplied one is used.
- Keep the USB cable away from other cables.

② Controller Cable (Supplied)

③ Power Antenna Lead

Connect this lead to the +B terminal of your power antenna, if applicable.

Note

- This lead should be used only for controlling the vehicle's power antenna. Do not use this lead to turn on an amplifier or a signal processor, etc.

④ Remote Turn-on Lead (Blue/White)

Connect this lead to the remote turn-on lead of your amplifier or signal processor.

⑤ Illumination Lead (Orange)

This lead may be connected to the vehicle's instrument cluster illumination lead. This will allow the backlighting of this unit to dim whenever the vehicle's lights are turned on.

⑥ Switched Power Lead (Ignition) (Red)

Connect this lead to an open terminal on the vehicle's fuse box or another unused power source which provides (+) 12V only when the ignition is turned on or in the accessory position.

⑦ Battery Lead (Yellow)

Connect this lead to the positive (+) post of the vehicle's battery.

⑧ Fuse Holder (15A)

⑨ Ground Lead (Black)

Connect this lead to a good chassis ground on the vehicle. Make sure the connection is made to bare metal and is securely fastened using the metal screw provided.

⑩ Front Right (+) Speaker Output Lead (Grey)

⑪ Front Right (-) Speaker Output Lead (Grey/Black)

⑫ Rear Right (-) Speaker Output Lead (Purple/Black)

⑬ Rear Right (+) Speaker Output Lead (Purple)

⑭ Rear Left (+) Speaker Output Lead (Green)

⑮ Rear Left (-) Speaker Output Lead (Green/Black)

⑯ Front Left (-) Speaker Output Lead (White/Black)

⑰ Front Left (+) Speaker Output Lead (White)

⑱ Controller Connection Terminal

⑲ Steering Remote Control Interface Connector

To steering remote control interface box.

For details, contact your Alpine dealer.

⑳ MIC Input Connector

To Microphone.

㉑ Rear USB Terminal

Use the supplied USB cable to connect it to the unit compatible iPod/iPhone or USB Memory/MTP (mobile phone).

Notes

- Only the unit compatible iPod/iPhone can be connected to the rear USB terminal. The front USB terminal does not support connection with iPod/iPhone.
- Do not connect a mobile phone or other charging device to the front USB terminal when an iPod/iPhone is connected. If you do so, normal performance of the unit cannot be guaranteed.

⑳ **Coaxial Output Terminal**

Connect to PXE-0850, etc (sold separately).

㉑ **RCA Pre-output/AUX Input Connector**

㉒ **Power Supply Connector**

㉓ **Microphone (Supplied)**

㉔ **Rear Aux Input Connector (Black)**

Using the commercially available adapter cable, the connector can input audio from an external device (e.g. portable player).

㉕ **Front Pre-output RCA Connector**

Red is on the right hand and white is on the left hand.

㉖ **Rear Pre-output RCA Connector**

Red is on the right hand and white is on the left hand.

㉗ **Subwoofer Output RCA Connector**

Red is on the right hand and white is on the left hand.

㉘ **RCA Extension Cable (sold separately)**

㉙ **Optical Output Terminal**

Connect to PXA-H800 or other audio processor (sold separately).

㉚ **Antenna Receptacle**

㉛ **Front USB Terminal**

Connect to USB Memory/MTP (mobile phone).

Note

- Do not connect charging devices to both front and rear USB terminals. If you do so, normal performance of the unit cannot be guaranteed.

To prevent external noise from entering the audio system.

- Locate the unit and route the leads at least 10 cm away from the car harness.
- Keep the battery power leads as far away from other leads as possible.
- Connect the ground lead securely to a bare metal spot (remove any paint, dirt or grease if necessary) of the car chassis.
- If you add an optional noise suppressor, connect it as far away from the unit as possible. Your Alpine dealer carries various noise suppressors, contact them for further information.
- Your Alpine dealer knows best about noise prevention measures. So consult your dealer for further information.